

STULZ

CLIMATE. CUSTOMIZED.

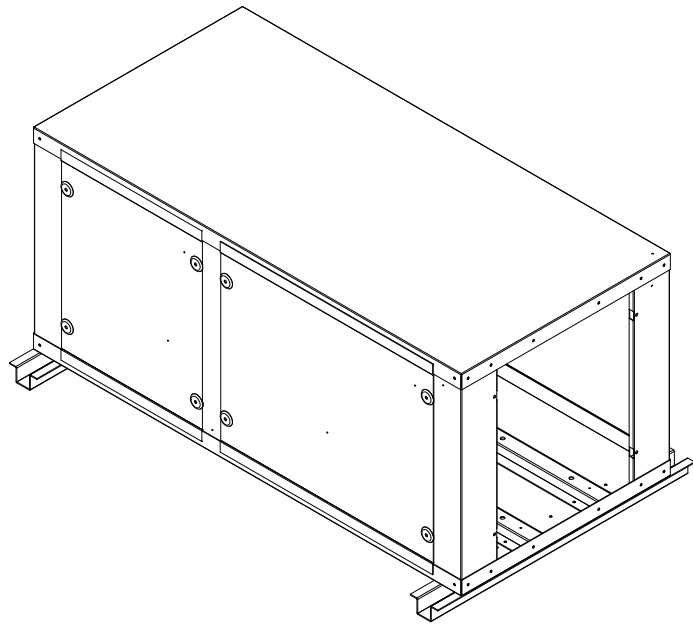
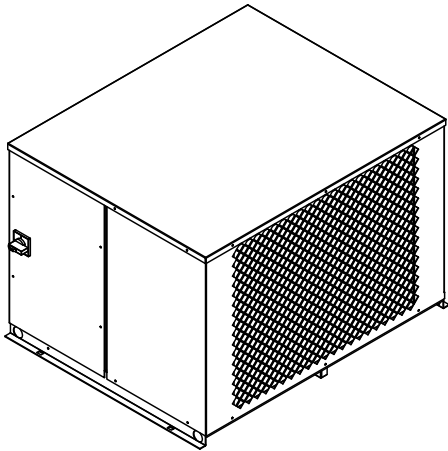

OHS Series RCU

**3–17 kW DX Air Cooled
Indoor and Outdoor
Remote Condensing Units**

Installation, Operation and Maintenance Manual

| Model Nomenclature | | | |
|-----------------------|---|----------------------------|-------------------------------------|
| OHS-XXX-XXX-X | | | |
| System | Capacity in 1,000s BTU/H | Unit | Outdoor/Indoor |
| OHS = Overhead System | 012 018 032 040 042 048 060 | RCU=Remote Condensing Unit | O = Outdoor unit I = Indoor unit |

Example: Outdoor OHS RCU, 42,000 BTU - **OHS-042-RCU-O**

Notice

This document contains information protected by copyright. All rights are reserved. The owner of the equipment for which this manual is written may photocopy the contents of this manual for internal use only. No part of this document may be photocopied, reproduced, or translated into another language for use by anyone other than the owner of the equipment for which this manual is written without the prior written consent of STULZ Air Technology Systems, Inc. (STULZ).

This document contains confidential and proprietary information of STULZ Air Technology Systems, Inc. Distributing or photocopying this document for external distribution is in direct violation of U.S. copyright laws and is strictly prohibited without the express written consent of STULZ.

Unpublished — rights reserved under the copyright laws of the United States and of other countries.

Other brands and tradenames are trademarks of their respective owners.

Copyright 2017 by STULZ Air Technology Systems, Inc.

Printed in the United States of America.

All rights reserved.

STULZ Air Technology Systems, Inc.

1572 Tilco Drive

Frederick, MD 21704, USA

Contents

| | | | |
|--|----------|--|-----------|
| 1.0 Introduction | 1 | 2.7.5.2 Saturated Refrigerant Pressure Tables | 14 |
| 1.1 General..... | 1 | 2.8 Settings and Adjustments | 15 |
| 1.2 Product Description | 1 | 2.8.1 High/Low Pressure Limit Switches | 15 |
| 1.2.1 Capabilities and Features..... | 1 | 2.8.2 Head Pressure Controls..... | 15 |
| 1.2.2 Application Ranges | 1 | 2.8.2.1 Condenser Fan Cycling..... | 15 |
| 1.2.3 General Design | 2 | 2.8.2.2 Condenser Fan Speed..... | 15 |
| 1.2.3.1 Compressor..... | 2 | 2.8.2.3 Flooded Head Pressure Control | 15 |
| 1.2.3.2 Condenser Coil..... | 2 | 2.8.3 Hot Gas Bypass | 16 |
| 1.2.3.3 Fan Assembly..... | 2 | 3.0 Commissioning and Decommissioning | 17 |
| 1.2.3.4 Electric Box | 2 | 3.1 Operation | 17 |
| 1.2.3.5 Circuit Breakers/Motor Starter Protectors..... | 3 | 3.2 Step by Step Start-Up Instructions..... | 17 |
| 1.2.3.6 Receiver | 3 | 3.3 Operational Description..... | 17 |
| 1.2.4 Safety Features..... | 3 | 3.4 Decommissioning the Unit..... | 18 |
| 1.3 Safety | 3 | 3.4.1 Recovering Refrigerant..... | 18 |
| 1.3.1 General..... | 3 | 3.4.2 Labeling Decommissioned Equipment..... | 18 |
| 1.3.2 Safety Summary..... | 3 | 4.0 Maintenance/Repairs | 19 |
| 2.0 Installation | 5 | 4.1 Periodic General Maintenance | 19 |
| 2.1 Receiving the Equipment..... | 5 | 4.1.1 General..... | 19 |
| 2.2 Site Preparation..... | 5 | 4.1.2 Compressor..... | 19 |
| 2.3 Rigging..... | 5 | 4.2 Troubleshooting | 19 |
| 2.4 Mounting/Placement..... | 5 | 4.3 Field Service..... | 23 |
| 2.5 Piping Connections | 6 | 4.3.1 Leak Detection..... | 23 |
| 2.5.1 Refrigerant Pipe Sizing..... | 7 | 4.3.2 Leak Repair | 23 |
| 2.5.1.1 Suction Line | 7 | 4.3.3 Refrigerant Piping..... | 23 |
| 2.5.1.2 Liquid Line | 8 | 4.3.4 General Common Repairs/Component Replacement | 23 |
| 2.6 Utility Connections..... | 8 | 4.3.4.1 Compressor Failure | 23 |
| 2.6.1 Main Power and Control Wiring..... | 8 | 4.3.4.2 Standard Cleanout Procedure..... | 24 |
| 2.6.2 Electric Box Layout..... | 10 | 4.3.4.3 Burn-Out/Acidic Cleanup Procedure | 24 |
| 2.7 System Charging | 10 | 4.3.4.4 Blower Belt Tensioning and Speed Adjustment . | 24 |
| 2.7.1 DX Charging Requirements | 10 | 5.0 Product Support..... | 26 |
| 2.7.2 R407C/R410A Refrigerant | 10 | 5.1 Technical Support | 26 |
| 2.7.3 Preparing System For Charging..... | 10 | 5.2 Obtaining Warranty Parts | 26 |
| 2.7.4 Refrigerant Charging Procedures..... | 11 | 5.3 Obtaining Spare/Replacement Parts | 26 |
| 2.7.4.1 Estimating Refrigerant Charge | 12 | Appendix A - Forms..... | 27 |
| 2.7.4.2 Introducing the Refrigerant Charge..... | 12 | Appendix B - Acronyms and Abbreviations..... | 29 |
| 2.7.4.3 -30 °F Flooded Head Pressure Control | 14 | | |
| 2.7.5 Refrigerant Characteristics..... | 14 | | |
| 2.7.5.1 Pressure/Temperature Settings | 14 | | |

Figures

| | |
|--|----|
| Figure 1. Typical Layout RCU-I (top) and RCU-O (bottom) .. | 2 |
| Figure 2. RCU-O Mounting | 5 |
| Figure 3. RCU-I Mounting..... | 6 |
| Figure 4. Piping Installation | 7 |
| Figure 5. RCU Field Wiring | 9 |
| Figure 6. Sample Nameplate | 9 |
| Figure 7. Refrigerant Charging Ports (RCU-O) | 13 |
| Figure 8. Refrigeration Cycle..... | 17 |
| Figure 9. Belt Drive Blower | 24 |

Tables

| | |
|--|----|
| Table 1. Standard Equivalent ft of Straight Pipe | 7 |
| Table 2. Vertical Pressure Drops for Refrigerants | 8 |
| Table 3. Recommended Liquid Line Sizes | 8 |
| Table 4. Recommended Suction Line Sizes | 8 |
| Table 5. Weight of Refrigerant (lb/ 100 ft, Type L)..... | 12 |
| Table 6. Standard Refrigerant Charge Weights | 12 |
| Table 7. Pressure/Temperature Settings for R407C..... | 14 |
| Table 8. Pressure/Temperature Settings for R410A..... | 14 |
| Table 9. Refrigerant Vapor Tables | 15 |

1.0 INTRODUCTION

1.1 General

STULZ manufactures two versions of the Remote Condensing Unit (RCU): One for outdoor installation (RCU-O) and one for indoor installation (RCU-I). This manual documents both types of RCU. The units are designed and manufactured by STULZ Air Technology Systems, Inc. (STULZ). Recognized as a world leader, STULZ provides precision cooling systems with the highest quality craftsmanship using the finest materials available in the industry. The unit will provide years of trouble free service if installed and maintained in accordance with this manual. Damage to the unit from improper installation, operation or maintenance is not covered by the warranty.

This manual contains information for installation, operation, maintenance, troubleshooting and repair. Spare parts are available from STULZ Air Technology Systems to insure continuous operation. Using substitute parts or bypassing electrical or refrigeration components in order to continue operation is not recommended and will void the warranty. Due to technological advancements, components are subject to change without notice.

STULZ RCU systems are designed to reject heat from refrigerant based cooling equipment. Any use beyond this is deemed to be not intended. STULZ is not liable for any damage resulting from improper use. The RCU-O system is designed to be installed outdoors unless otherwise noted on the equipment nameplate. The RCU-I is designed for indoor installation only.

1.2 Product Description

STULZ RCUs are air-cooled, heat rejection condensing systems with horizontal air discharge. The units are contained in a light weight, corrosion resistant aluminum cabinet designed for mounting to a horizontal surface (RCU-O) or suspension from a ceiling (RCU-I). The cabinet houses the compressor, condenser coil, fan assembly, sight glass and receiver (optional). The electrical controls in the RCU-O and RCU-I are in an integrally mounted electric box enclosure which is isolated from the rest of the equipment. The electric box on the RCU-O is weatherproof. There are several cabinet sizes based on the capacity of the unit. Refer to the installation drawing supplied with your unit for the layout and dimensions of the cabinet.

The cooling capacity in BTU/H will depend on the unit size which can range from 12,000 to 60,000 BTU/H. The condensing system is a closed-loop circuit in which refrigerant is continuously circulated by a pressure differential created by the compressor. The compressor is designed to

increase refrigerant pressure to a level sufficiently high for it to be cooled and condensed into liquid by the effect of ambient air being drawn over the condenser coil.

Both RCUs use fan cycling for low ambient head pressure control down to 0 °F. Flooded head pressure control is used for low ambient temperatures down to -30 °F.

STULZ RCU systems are designed to operate with either R407C or R4-10A refrigerant. Refer to the unit nameplate to identify the model number and which refrigerant is used with your unit.

NOTE

STULZ RCU systems are strictly for non-residential applications.

Operation of the RCU is controlled by a 24 VAC input signal from a system controller provided with the refrigeration equipment.

1.2.1 Capabilities and Features

- All Aluminum Cabinet Construction.
- Aluminum Fin Copper Tube Coil Construction.
- Vibration Isolation of Compressor.
- Fan Motor Equipped With Permanently Lubricated Motor Bearings.
- Removable Lid Allows Access To All Components (RCU-O only).
- Compact Profile With Internal Control Enclosure.

1.2.2 Application Ranges

STULZ RCU systems are designed for operation within the following ranges:

Outdoor Temperature Range:

- Fixed Fan Cycling Control..... 0 to 95 °F.
- Variable Fan Speed Control -20 to 95 °F.
- Flooded Head Pressure Control..... -30 to 95 °F.

Operating Voltage: VAC Input per unit nameplate +/- 10%.

Max. Piping Length; Evaporator to RCU:

- 100 ft equivalent length.
- (50 equivalent ft if equipped with hot gas bypass.)

Max. Vertical Level Drop; Refrigeration Equipment to RCU:

- 15 ft (when RCU is below the evaporator).

Storage Conditions: -30 to 105 °F.

NOTE

Damage or malfunction to the unit due to storage or operation outside of these ranges will void the warranty.

1.2.3 General Design

Figure 1 depicts a typical layout of the RCU-I and RCU-O and identifies their major components.

1.2.3.1 Compressor

The compressor is mounted inside the unit on vibration absorbers to eliminate noise and vibration during operation. Compressors are equipped with crankcase heaters to prevent refrigerant from migrating into the compressor during the off cycle, permitting smoother start-ups.

1.2.3.2 Condenser Coil

The condenser coil is rated at the capacity indicated by the unit model number. It is a copper tube, aluminum finned coil.

1.2.3.3 Fan Assembly

The RCU-O uses a propeller type aluminum, multi-blade fan with a direct drive motor. The motor is equipped with internal

overload protection and is protected from over current by a motor starter protector located in the electric box. The 012-040 model RCU-I use a direct-drive blower. The larger capacity RCU-I units have a belt-driven blower with separate drive motor.

1.2.3.4 Electric Box

RCU electrical components are protected in an enclosure located inside the RCU unit behind a removable front access panel. This panel on the RCU-O is safety interlocked with the service disconnect switch, preventing the panel from being removed when the switch is in the "On" position. A factory-installed electrical disconnect switch is available as an option with the RCU-I, otherwise a customer-provided electrical disconnect switch should be field installed.

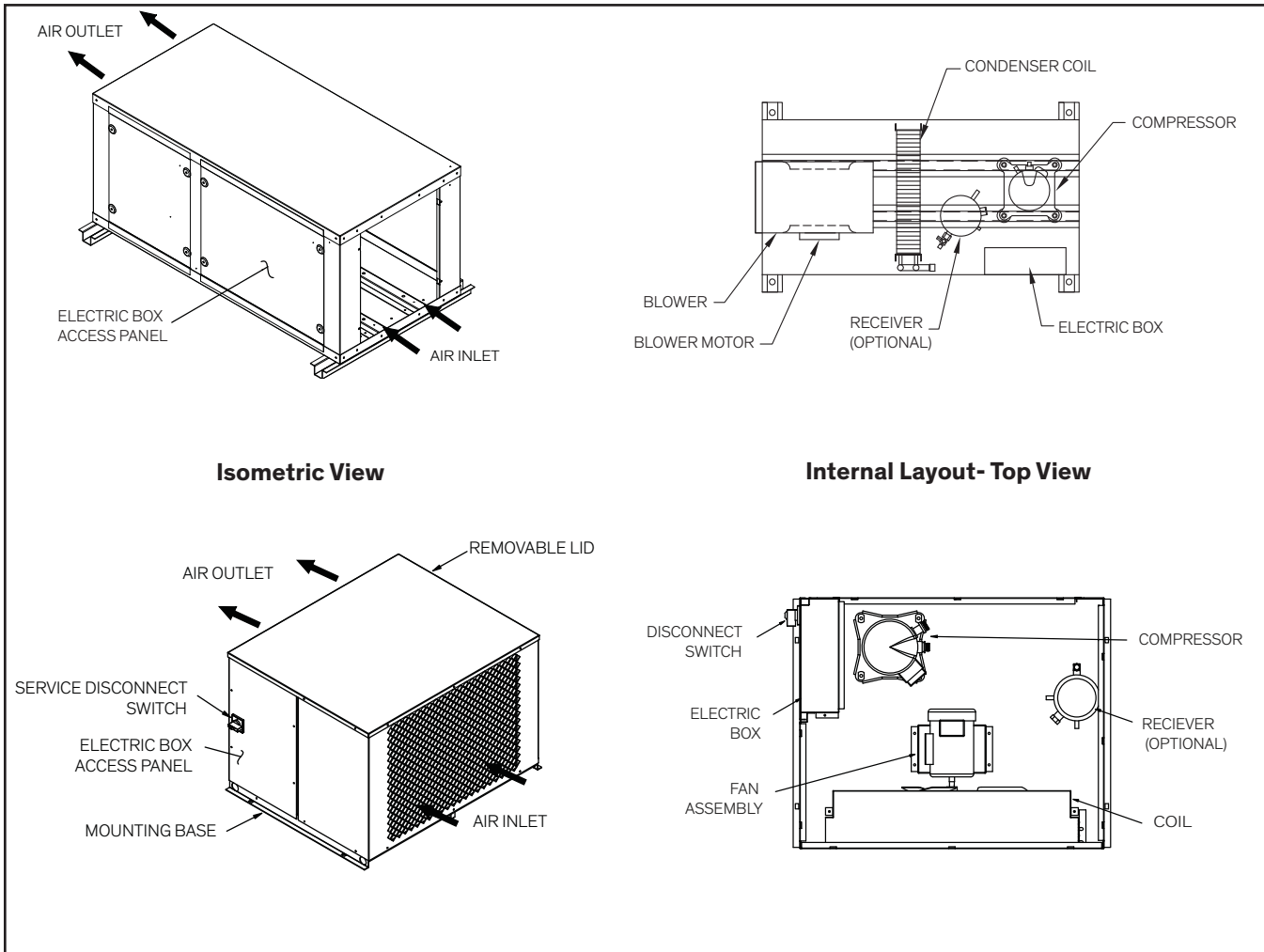

Figure 1. Typical Layout RCU-I (top) and RCU-O (bottom)

1.2.3.5 Circuit Breakers/Motor Starter Protectors

Individual overload protection is provided by circuit breaker(s), and motor starter protectors. These switches open to de-energize a failed component if an electrical overload condition is encountered. They must be manually reset once the overload condition is cleared.

1.2.3.6 Receiver

An optional receiver is provided for storage of excess refrigerant in the refrigeration cycle. Typically used on RCU-O units for cold weather applications, the receiver is provided for units using flooded head pressure control.

1.2.4 Safety Features

A factory-mounted service disconnect switch is provided as standard on RCU-O units and as an option on RCU-I units. A service disconnect switch electrically isolates the unit during routine maintenance. The handle of the switch may be locked in the "Off" position to prevent unauthorized operation. RCU units incorporate state of the art component protection with the use of motor starter protectors and circuit breakers.

Low and high-pressure switches are provided for the refrigeration circuit. The pressure switches are non-adjustable encapsulated control switches. If a high pressure switch is tripped for any reason, it must be manually reset. The cause for tripping the high pressure switch must be determined. The low pressure switches reset automatically. These pressure switches are installed as safety devices and help prevent compressor failure or other serious damage to the system.

1.3 Safety

1.3.1 General

STULZ Air Technology Systems, Inc. uses **NOTES** along with **CAUTION** and **WARNING** symbols throughout this manual to draw your attention to important operational and safety information.

A bold text **NOTE** marks a short message in the information to alert you to an important detail.

A bold text **CAUTION** safety alert appears with information that is important for protecting your equipment and performance. Be especially careful to read and follow all cautions that apply to your application.

A bold text **WARNING** safety alert appears with information that is important for protecting you from harm and the equipment from damage. Pay very close attention to all warnings that apply to your application.

A safety alert symbol  accompanies a general **WARNING** or **CAUTION** safety statement.

A safety alert symbol  accompanies an electrical shock hazard **WARNING** or **CAUTION** safety statement.

1.3.2 Safety Summary

The following statements are general guidelines followed by warnings and cautions applicable throughout the manual.

Prior to performing any installation, operation, maintenance or troubleshooting procedure, read and understand all instructions, recommendations and guidelines contained within this manual.

WARNING

High voltage is used in the operation of this equipment. Death on contact may result if personnel fail to observe safety precautions.

WARNING

R407C or R410A refrigerant is used with this equipment. Death or serious injury may result if personnel fail to observe proper safety precautions. Do not allow contact of liquid refrigerant or refrigerant gas, discharged under pressure, with any part of the body. The extremely low temperature resulting from the rapid expansion of liquid refrigerant or pressurized gas can cause sudden and irreversible tissue damage.

All personnel should wear thermal protective gloves and face-shield/goggles when working with refrigerant. Application of excessive heat to any component will cause extreme pressure and may result in a rupture.

Exposure of refrigerant to an open flame or very hot surface can produce fluorophosgene, a highly poisonous, corrosive gas. In its natural state, refrigerant is a colorless, odorless vapor with no toxic characteristics. It is heavier than air and will disperse rapidly in a well-ventilated area. In an unventilated area, it presents a danger as a suffocant.

Always refer to the manufacturer's safety data sheet (SDS) provided with the unit.

WARNING

Avoid skin contact or inhaling fumes from any acid formed by burn out of oil and refrigerant. Wear gas mask if area is not thoroughly ventilated. Wear protective goggles or glasses to protect eyes. Wear rubber gloves to protect

hands. Use care to avoid spilling compressor burnout sludge. If sludge is spilled, clean area thoroughly.

WARNING 

When performing soldering or de-soldering operations, make certain the refrigeration system is fully recovered and purged and dry nitrogen is flowing through the system at the rate of not less than 1-2 CFM.

CAUTION 

All maintenance and/or repairs must be performed by a journeyman, refrigeration mechanic or an air conditioning technician.

CAUTION 

Never lift any component in excess of 35 pounds without help. If a lifting device is used to move a unit, ensure it is capable of supporting the unit.

CAUTION 

Do not allow the unit to swing while suspended from a lifting device. Failure to observe this warning may result in injury to personnel and damage to the equipment.

CAUTION 

Do not allow anyone under the equipment suspended from a lifting sling.

CAUTION 

The unit must be kept in its normal installed position. If the unit is not kept level and vertical, damage to the unit's compressor will result.

CAUTION 

When working on electrical equipment, remove all jewelry, watches, rings, etc. Keep one hand away from the equipment to reduce the hazard of current flowing through vital organs of the body.

CAUTION 

Always disconnect the main power supply to the equipment at the main power disconnect switch before beginning work on the equipment. A lock-out tag-out procedure should be followed to ensure that power is not inadvertently reconnected.

CAUTION 

Equipment may contain ESD (Electrostatic Discharge)-sensitive electronic components. Before touching these components, ensure you have no charge built up by touching a ground source. When possible, use a wrist-grounding strap when working on or near electronic devices.

CAUTION 

Never work on electrical equipment unless another person who is familiar with the operation and hazards of the equipment and competent in administering first aid is nearby.

CAUTION 

All personnel working on or near equipment should be familiar with hazards associated with electrical maintenance. Safety placards/stickers have been placed on the unit to call attention to all personal and equipment damage hazard areas.

CAUTION 

Ensure the unit is properly phased. Improper phasing can cause severe damage to the compressor.

CAUTION 

Certain maintenance or cleaning procedures may call for the use and handling of chemicals, solvents, or cleansers. Always refer to the manufacturer's safety data sheet (SDS) prior to using these materials. Clean parts in a well-ventilated area. Avoid inhalation of solvent fumes and prolonged exposure of skin to cleaning solvents. Wash exposed skin thoroughly after contact with solvents.

CAUTION 

Do not use cleaning solvents near open flame or excessive heat. Wear eye protection when blowing solvent from parts. The pressure-wash should not exceed 30 psig. Solvent solutions should be disposed of in accordance with local and state regulatory statutes.

CAUTION 

Remote condensing units are shipped from the factory with a dry nitrogen holding charge which must be removed before piping the unit.

2.0 INSTALLATION

2.1 Receiving the Equipment

Your RCU system has been tested and inspected prior to shipment. To ensure the equipment is received in factory condition, visually inspect the equipment immediately upon delivery. Carefully remove the shipping container and all protective packaging. Open the access doors and thoroughly inspect the unit interior for any signs of transit-incurred damage. If there is shipping damage, it must be noted on the freight carrier's delivery forms before signing for the equipment. STULZ ships all equipment FOB factory and is not liable for any equipment damage while in transit. Freight claims must be made through the freight carrier; however, STULZ can assist in the claim filing process with the freight carrier. Should any such damage be present, notify STULZ Product Support prior to attempting any repairs. Refer to "5.0 Product Support" on page 26 of this manual for instructions.

Check the equipment against the packing slip to verify the shipment is complete. Report all discrepancies to STULZ.

A Data Package was sent with your unit. It contains this manual, system drawings, applicable SDS's and other applicable instructions based on the configuration and options of your unit. The data package has been placed in a clear plastic envelope. These documents need to be kept with the unit for future reference.

2.2 Site Preparation

STULZ RCU systems are designed with easy service access in mind. Install the RCU in a secure location where the unit cannot be tampered with and the main power disconnect switch cannot be inadvertently turned off. Allow access to the unit for routine operation, servicing and for necessary maintenance. Refer to the installation drawing provided with your unit for the dimensions of the RCU.

NOTE

Working clearance requirements need to be established prior to the mounting of the unit. Refer to local and national electrical codes.

NOTE

Equipment must be level to operate properly.

2.3 Rigging

The RCU system is designed to be kept level in a vertical position. Move the unit with a suitable device such as a forklift or attach an overhead lifting sling, supporting the unit from the

mounting base. Use an appropriate capacity lifting device that can safely handle the weight of the equipment. Weight tables are provided on the installation drawing provided in the unit Data Package. If using an overhead lifting device, utilize lifting bars that exceed the cabinet width in order to avoid crushing the sides of the unit. Remote Condensing Units are shipped on a skid to facilitate moving prior to installation. Units should always be stored in a dry location prior to installation.

CAUTION

The unit must be kept level when lifting to prevent damage to the compressor

2.4 Mounting/Placement

2.4.1 Mounting/Placing the RCU-O

The RCU-O is designed for mounting to a flat surface. Install the RCU-O in a secure location with adequate space for accessing components for installation, maintenance and repair procedures. The refrigeration components are accessed through the top by removing the lid, and from the back by removing the rear air discharge panel. The electric box is accessed from the side of the unit. Locate the unit where the fan is not likely to draw dirt and debris into the coil fins.

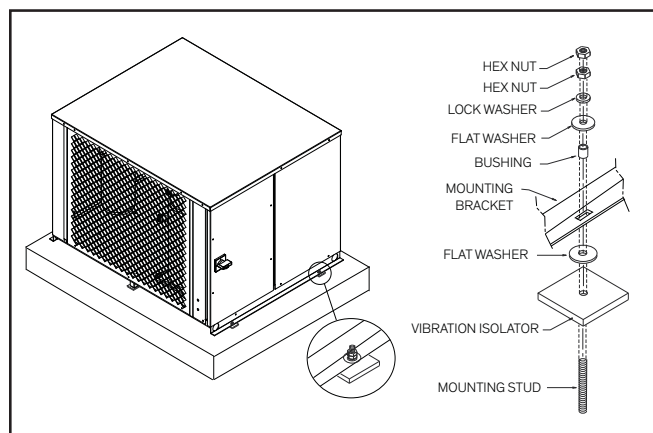

Figure 2. RCU-O Mounting

Condensing units must not be located in the vicinity of steam, hot air or fume exhausts. The clearance around the unit should be at least 1 times (1X) the unit's width to ensure adequate airflow to the coil. Space multiple units so that hot condensing exhaust air is not directed toward the air inlet of an adjacent unit. Avoid areas where heavy snow will accumulate at air inlet and outlet openings. If possible, make use of terrain features such as trees and buildings to provide a shaded location. This will minimize the solar load on the unit. Avoid ground level sites that are accessible to the public.

Install a solid base, capable of supporting the weight of the

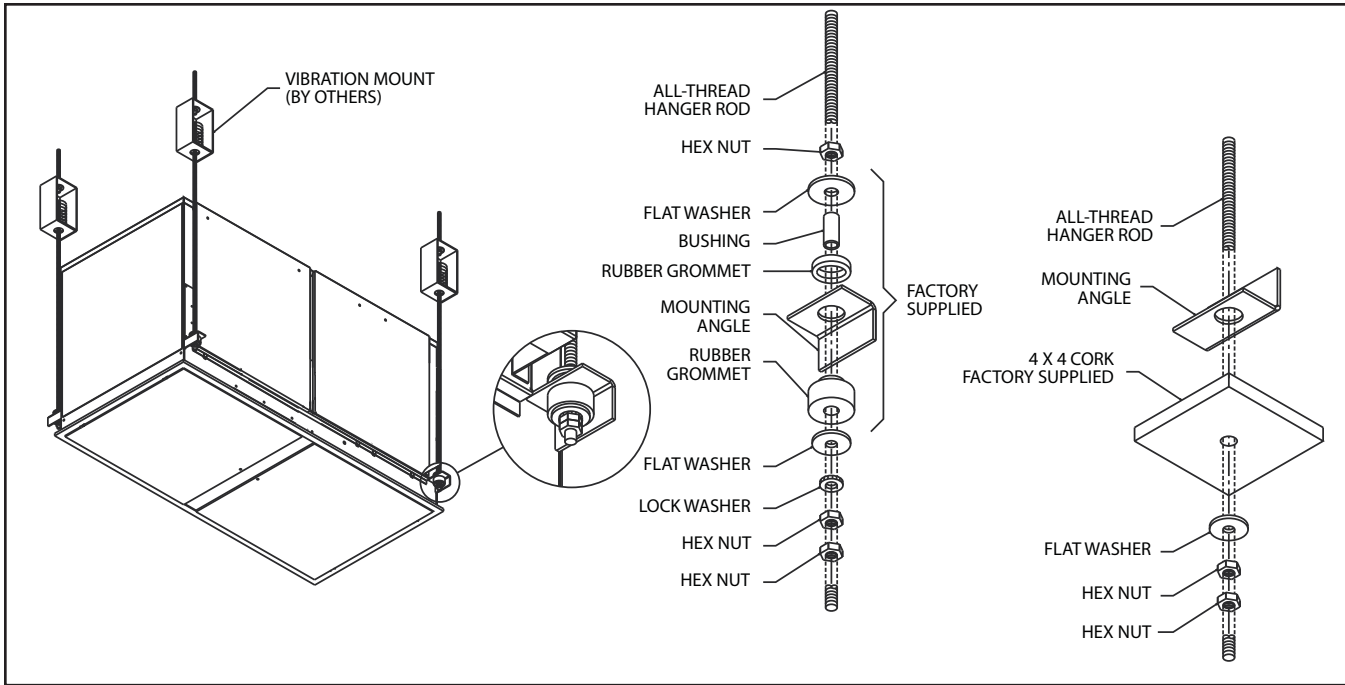

Figure 3. RCU-I Mounting

equipment. Reference the installation drawing for the non-charged system weight. The base should be at least 2 in. higher than the surrounding grade and 2 in. larger than the dimensions of the condensing unit base (see Figure 2).

Insert the factory provided vibration isolators between the RCU-O and the base as shown in Figure 2 to reduce the amount of vibration transmitted to the mounting surface. Secure the unit with fasteners (field supplied by others) so that the system will not move during operation.

2.4.2 Mounting/Placing the RCU-I

RCU-I systems are designed for ceiling mounting in a suspended ceiling grid (spot cooler) or above the suspended ceiling for ducted systems. See Figure 3.

NOTES

- Do not install the A/C system directly above electronic equipment that may hinder serviceability.
- Equipment must be level to operate properly

2.5 Piping Connections

Split air-cooled systems require a field installed copper suction line and copper liquid line between the RCU and the evaporator. Refer to the refrigeration diagram provided with your unit for piping details. Use standard refrigeration practices for piping, supports, leak testing, dehydration and charging of the refrigeration circuits.

NOTE

STULZ RCU units are shipped pressured, with a dry nitrogen holding charge. Before installing the interconnecting piping, observe appropriate safety precautions and release the pressure via an available stem valve or schrader valve prior to uncapping the pipes.

STULZ RCU units can use either R407C or R410A refrigerant. All refrigeration piping should be installed with high temperature brazed joints. The refrigeration piping should be isolated from the building by the use of vibration isolating supports. Provide supports (clamps or hangers) as necessary every 5 to 10 ft along piping runs to minimize vibration and noise transmission. To prevent tube damage when sealing openings in walls and to reduce vibration transmission, use a soft flexible material to pack around the tubes.

Wrap wet rags around the pipes between the areas to be soldered and any nearby refrigeration components to keep excessive heat from traveling through the pipe and causing damage. Clear all pipe connections of debris and prepare the connections for soldering. Use only “L” or “K” grade refrigerant copper piping. Dry nitrogen should be flowing through the tubing while soldering at a rate of not less than 1-2 CFM. Be careful not to allow solder/piping debris to get inside refrigerant lines.

When brazing copper-to-copper connections (piping liquid line or suction line), use a phosphorus copper brazing alloy with 15% silver. General purpose silver brazing alloy with 45% silver is to be used for copper-to-brass or copper-to steel.

NOTE

R410A refrigerant operates at significantly higher pressures than R407C refrigerant.

2.5.1 Refrigerant Pipe Sizing

Refrigerant lines for split systems must be sized according to the piping distance between the evaporator and the condenser. Each valve, fitting and bend in the refrigerant line must be considered in this calculation. Refer to the following chart for standard equivalent lengths, in feet, of straight pipe.

The general guidelines in Table 1 may be used to assist in determining the size of the refrigerant lines between the evaporator section and the remote condensing unit.

Table 1. Standard Equivalent ft of Straight Pipe

| Equivalent Length (ft) of Straight Pipe | | | | | | |
|---|----------------|----------------|--------------|--------------|-------------|---------------|
| OD (in.) Line Size | Globe Valve | Angle Valve | 90° Elbow | 45° Elbow | Tee Line | Tee Branch |
| 1/2 | 9.0 | 5.0 | 0.9 | 0.4 | 0.6 | 2.0 |
| 5/8 | 12 | 6.0 | 1.0 | 0.5 | 0.8 | 2.5 |
| 7/8 | 15 | 8.0 | 1.5 | 0.7 | 1.0 | 3.5 |
| 1 1/8 | 22 | 12 | 1.8 | 0.9 | 1.5 | 4.5 |
| 1 3/8 | 28 | 15 | 2.4 | 1.2 | 1.8 | 6.0 |
| 1 5/8 | 35 | 17 | 2.8 | 1.4 | 2.0 | 7.0 |
| 2 1/8 | 45 | 22 | 3.9 | 1.8 | 3.0 | 10 |
| 2 5/8 | 51 | 26 | 4.6 | 2.2 | 3.5 | 12 |
| 3 1/8 | 65 | 34 | 5.5 | 2.7 | 4.5 | 15 |
| 3 5/8 | 80 | 40 | 6.5 | 3.0 | 5.0 | 17 |

Refer to the tables on the following pages showing the recommended suction and liquid line pipe sizes for the A/C system you are installing. Things to consider when sizing refrigerant piping are the varying BTU capacities of indoor evaporators and the equivalent length of pipe needed between the remote condensing unit and the evaporator. If the pressure drop is too high, the capacity of the compressor decreases and the power required increases. An excessive refrigerant charge will be used if the volume of the piping is too large.

NOTE

The size of the equipment pipe connections does not indicate the size of the refrigerant lines to be used. In cases where the pipe size doesn't match the size of the connection, reducing fittings should be used to transition between the connection and the pipe.

2.5.1.1 Suction Line

If the condenser is installed above the evaporator, the suction line should include a shallow P-trap at the lowest point in the piping (see Figure 4). The highest point in the suction line should be above the condenser coil. Additionally, shallow P-traps must be included in the suction line for every 20 ft of vertical rise. All horizontal refrigerant lines should be pitched in the direction of flow at least 1/4 in. for every 10 ft.

NOTE

All suction lines should be insulated to prevent condensation from forming.

Figure 4 shows a typical piping diagram for when the condenser is located at a higher level than the evaporator. In this situation it's important to size the suction line properly. If the suction line is sized correctly for full load operation, the velocity of the gas may be too low during minimum load conditions to carry the refrigerant oil up the suction line to the compressor. Decreasing the size of the suction line will increase refrigerant velocity however, it will also restrict the flow of refrigerant at full load conditions creating an excessive refrigerant pressure drop. Ensure the suction line is sized to maintain a minimum velocity of 700 fpm of refrigerant in horizontal lines and 1500 fpm of refrigerant in vertical lines. This will ensure the refrigerant flows at a velocity high enough for the refrigerant vapor to carry the oil with it to the compressor.

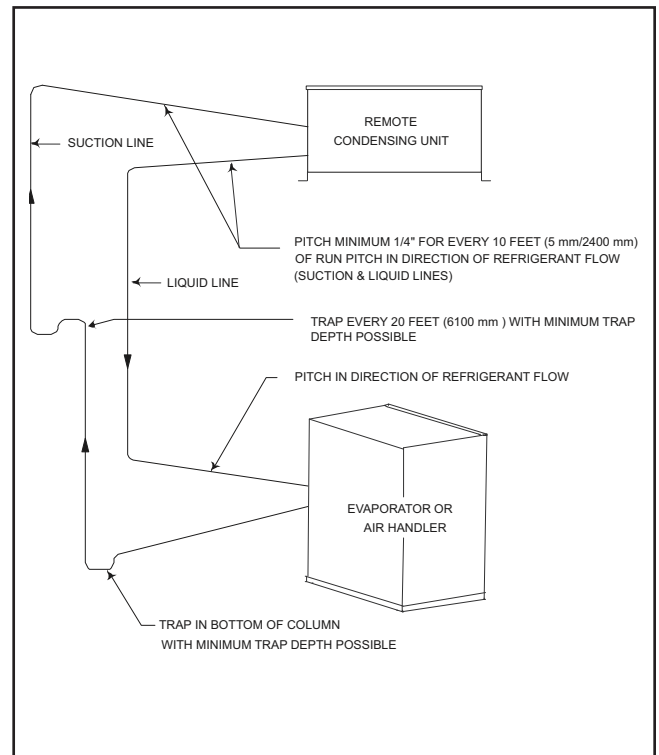

Figure 4. Piping Installation

Suction piping is typically sized for a total friction pressure drop equivalent to 2 °F evaporator temperature.

If the RCU is installed below the evaporator, the suction line should include an inverted trap the height of the evaporator coil. This prevents migration of liquid refrigerant to the compressor during off cycles (see Figure 4).

NOTE

Do not exceed 15 ft vertical distance when installing the condensing unit below the evaporator.

If the condenser is installed below the evaporator section, the installer must observe the pressure changes that occur as a result of the elevation change. See the table that follows for the vertical pressure drops for the two types of refrigerant used.

Table 2. Vertical Pressure Drops for Refrigerants

| Refrigerant Type | Pressure Drop in PSI/ft (Risers) |
|------------------|----------------------------------|
| R407C | .47 |
| R410A | .43 |

2.5.1.2 Liquid Line

The velocity of refrigerant in the liquid line is less critical because liquid refrigerant and oil are mixed thoroughly in the liquid state. The main concern when sizing the liquid line is to maintain a solid liquid head of liquid refrigerant entering the thermostatic expansion valve (TXV). If the refrigerant pressure falls below its saturation temperature, a portion of the liquid refrigerant changes into vapor. Vapor will cause flashing and prevent the TXV from functioning properly. As flashing begins, the rate of pressure loss increases.

During operation the liquid refrigerant is sub-cooled slightly below its saturation temperature. Sub-cooling must be sufficient to allow the necessary pressure drop without approaching a saturation condition where gas flashing could occur. Under normal operation, the refrigerant is sufficiently cooled as it leaves the condenser to allow for normal line pressure drops. Liquid line size is to be selected based on a pressure drop equivalent to 2 °F sub-cooling.

Operating liquid line velocities should be less than 300 fpm to avoid liquid hammering during solenoid operation.

Refer to Table 3 and Table 4 for recommended line sizing.

NOTE

Vertical runs are based on a total rise of 30 equivalent ft. For longer rises, individual calculations must be made. Sizes assume the use of single risers; double risers may be necessary.

Table 3. Recommended Liquid Line Sizes

| Recommended Liquid Line Sizes | | |
|--------------------------------------|-----------------------------------|-------------|
| Model No./ Total Unit Capacity BTU/H | RCU To Evaporator- Equivalent ft* | |
| | 50 or less | 100 or less |
| 012 / 12,000 | 3/8 | 3/8 |
| 018 / 18,000 | 3/8 | 3/8 |
| 024 / 24,000 | 3/8 | 1/2 |
| 032 / 32,000 | 1/2 | 1/2 |
| 040 / 40,000 | 1/2 | 5/8 |
| 042 / 42,000 | 1/2 | 5/8 |
| 048 / 48,000 | 1/2 | 5/8 |
| 060 / 60,000 | 1/2 | 5/8 |

Table 4. Recommended Suction Line Sizes

| Recommended Suction Line Sizes | | | | |
|--------------------------------|-----------------------------------|-------|-------------|-------|
| Capacity BTU/H | Evaporator To RCU- Equivalent ft* | | | |
| | 50 or less | | 100 or less | |
| | H | V | H | V |
| 12,000 | 5/8 | 5/8 | 5/8 | 5/8 |
| 18,000 | 7/8 | 7/8 | 7/8 | 7/8 |
| 24,000 | 7/8 | 7/8 | 7/8 | 7/8 |
| 32,000 | 7/8 | 7/8 | 1-1/8 | 7/8 |
| 40,000 | 1-1/8 | 1-1/8 | 1-1/8 | 1-1/8 |
| 42,000 | 1-1/8 | 1-1/8 | 1-1/8 | 1-1/8 |
| 48,000 | 1-1/8 | 1-1/8 | 1-1/8 | 1-1/8 |
| 60,000 | 1-1/8 | 1-1/8 | 1-1/8 | 1-1/8 |

H= Horizontal Run; V= Vertical Run

*Equivalent ft accounts for the linear pipe length as well as equivalent length of Valves, Elbows & Tee's as shown in the previous chart.

2.6 Utility Connections

2.6.1 Main Power and Control Wiring

Systems equipped with an RCU require field wiring between the RCU and the system controller (see Figure 5). The RCU unit is provided with main power and control terminal positions for connection of the field-wiring (supplied by others). It is important to identify the options that were purchased with the unit in order to confirm which field connections are required. Refer to the electrical drawing supplied with the unit to determine the total number of interconnecting conductors required for your system.

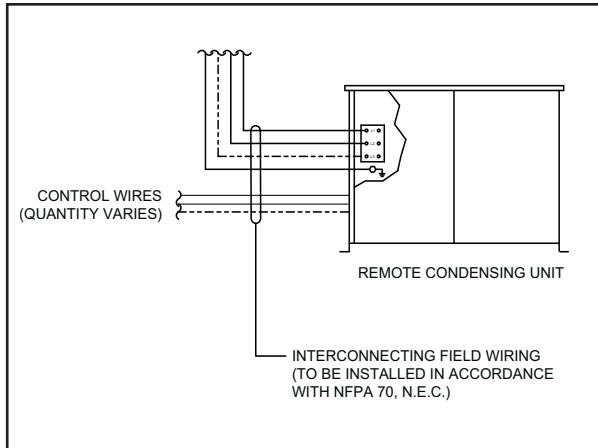

Figure 5. RCU Field Wiring

The RCU is available in the following voltage configurations:

- 208-230 VAC 1-phase
- 208-230 VAC 3-phase
- 277 VAC 1-phase
- 460 VAC 3-phase
- 575 VAC 3-phase

Verify that the main power supply coincides with the voltage, phase and frequency information specified on the system nameplate. The supply voltage measured at the unit must be within $\pm 10\%$ of the voltage specified on the nameplate (see Figure 6). The nameplate also provides the full load amps (FLA), the current that the unit will draw under full design load, the minimum circuit ampacity (MCA) for wire sizing, and the maximum fuse or HACR (Heating, Air Conditioning, Refrigeration) breaker size (MAX FUSE/CKT BKR) for circuit protection. The unit's nameplate is located inside the cabinet within the electrical box.

Pilot hole openings for the conduit are located in the side of the electric box. A label stating "MAIN POWER INPUT" is in close proximity. The main power wires are terminated at the line side of the service disconnect switch located within the electric box. A separate equipment ground lug is provided within the electrical box for termination of the earth ground wire.

The installer must also wire control conductors from the terminal board within the RCU unit to the system controller. The number of control conductors needed will vary depending on the type of control being used with your equipment. Refer to the electrical drawing supplied with your unit to determine the correct quantity of control conductors needed and for the proper wire terminations.

Manufactured By



STULZ Air Technology Systems, Inc.
 Frederick, Maryland, USA
 www.stulz-usa.com
 Cage Code OB716
 Tel: (301) 620-2033
 Fax: (301) 620-1396

Sales Order Number: MET TEST UNIT_HES
 Model Number: HES-120-CAA
 Item Number: 195401
 Serial Number: -



Electrical Data:
 SCCR: 1 kA RMS Symmetrical
 Voltage: 575 Phase: 3 Hz: 60
 No. Wires: 4 (Including Ground)
 FLA: 0.5 MCA: 0.6
 Max Fuse / Ckt. Bkr (HACR type per NEC): 15 A

Heater: - kW (Nominal)
 Humidifier: - kW (Nominal)

| | | |
|-----------------------|--------|--------|
| Evaporator Motor (1): | HP: - | FLA: - |
| Evaporator Motor (2): | HP: - | FLA: - |
| Evaporator Motor (3): | HP: - | FLA: - |
| Evaporator Motor (4): | HP: - | FLA: - |
| Condenser Motor (1): | HP: 0 | FLA: 0 |
| Condenser Motor (2): | HP: - | FLA: - |
| Condensate Pump: | HP: - | FLA: - |
| Compressor (1): | RLA: - | LRA: - |
| Compressor (2): | RLA: - | LRA: - |

Refrigerant Type: R407C
 Charge: Circuit #1 lb oz
 Charge: Circuit #2 lb oz

High Side Design Pressure: 278 psig
 Low Side Design Pressure: 144 psig

Max. Output Air Temperature: - °F
 Blower/Fan Ext. Static Press.: 0.5 in. w.g.

Max. Inlet Hot Water Temp.: - °F
 Hot Water or Steam Pressure: - psig

Minimum Installation Clearance: 0.0 in.

Remote Condenser Type: AIR COOLED

Suitable for Indoor: X Outdoor: Use

Date of Manufacture: 11/17

Q.A. Acceptance:

Figure 6. Sample Nameplate

⚡ WARNING

High voltage is used in the operation of this equipment. Death on contact may result if personnel fail to observe safety precautions.

⚡ WARNING

Verify power is turned off before making connections to the equipment.

NOTE

All wiring must conform to local and national electrical code requirements. Use of copper conductors only is required. Wiring terminations may become loose during transit of the equipment; therefore, it is required to verify that all wiring terminations are secure.

It is important to note that the control transformer supplied with the equipment is sized and selected based upon the expected load for the system.

CAUTION

Do not connect any additional loads to the system control transformer. Connecting additional loads to the factory supplied control transformer may result in overloading of the transformer, which will cause the transformer circuit breaker to trip.

CAUTION

Improper wire connections will result in the reverse rotation of the fan and compressor and may eventually result in damage to the compressor. To correct this problem, exchange any two of the incoming main power wires at the main power circuit breaker. Do not rewire the unit's individual components.

2.6.2 Electric Box Layout

The electronic components in the RCU electric boxes are labeled with reference designators which are named in the unit electrical drawings. See those drawings for the location and identity of specific electric box components.

2.7 System Charging

2.7.1 DX Charging Requirements

When performing the specific DX charging procedures in this section, follow these best practices:

- Ensure that contamination of different refrigerants does not occur when using charging equipment. Hoses or lines must be as short as possible to minimize the amount of refrigerant contained in them.
- Keep cylinders upright.
- Ensure the refrigeration system is grounded to Earth before charging the system with refrigerant.
- Label the system when charging is complete (if it is not labeled already).
- Exercise extreme care to avoid overfilling the refrigeration system.

Before recharging the system, it must be pressure tested with oxygen-free nitrogen (OFN). The system must be leak tested upon completion of charging but prior to commissioning. A follow-up leak test must be carried out prior to leaving the site.

2.7.2 R407C/R410A Refrigerant

R407C and R410A are blended refrigerants recognized for being safer for the environment. These refrigerants contain no chlorine, the component in HCFC's that destroy the earth's ozone layer. However, the same care should be taken to prevent leakage because R407C and R410A can contribute to the greenhouse effect if released. If the refrigerant gas is released in an enclosed space, it can become a suffocant.

Refrigerants that are multi-component blends have component parts with different volatilities that result in a change in composition and saturation temperature as evaporation and condensation occur. Typically, the composition of R407C vapor is different than that of R407C liquid within a contained system. The composition of liquid R407C refrigerant remains relatively constant, however, the refrigerant vapor tends to separate into its component parts even when circulating.

Refrigerant R410A is similar to R407C in that it is a blended refrigerant that consists of component parts, however, the component parts of R410A refrigerant have the same composition at various operating temperature/pressures in the liquid phase and gas phase reducing the temperature glide effect experienced with R407C. R410A operates at higher pressures than R407C which must be considered when checking the operating temperatures/pressures while charging or troubleshooting the system.

2.7.3 Preparing System For Charging

NOTE

Refrigerant charging must be performed by a journeyman, refrigerant mechanic or an air conditioning technician.

1. With all the system piping connections made, perform a dry nitrogen leak detection test on the system. Using dry nitrogen only, pressurize the system to 150 psig. Ensure all service and solenoid valves are energized open and that no part of the system is isolated from the pressurized nitrogen (liquid, suction or discharge lines and reheat coil).
2. Since there is no refrigerant in the system to detect at this point, leaks may be detected by observing if there's been a change in the standing pressure after 12 hours. A significant drop in pressure indicates a leak in the system that needs to be repaired. After the system is determined to be free of leaks, you may evacuate the system.

EVACUATE THE SYSTEM

CAUTION

A proper vacuum must be drawn on the refrigerant system to remove moisture prior to charging. If this is not done the refrigerant charge will combine with moisture in the pipes to form an acid that will eventually lead to compressor failure. A triple evacuation procedure with dry nitrogen is recommended especially for systems with newly installed refrigerant piping.

NOTE

Use a vacuum pump capable of evacuating the entire volume of the A/C system, including newly installed or existing piping. It is essential to use a well maintained pump that is in good operating condition.

NOTE

Use high quality hoses ensuring they are free of defects and don't leak. It is recommended to use copper tubing instead of hoses if possible due to the low vacuum that must be attained when evacuating the system. The use of short, large diameter hoses helps reduce evacuation time.

3. After ensuring there are no leaks, relieve pressure and evacuate the entire system while maintaining all the solenoids and hot gas reheat valves open. Pull an initial vacuum of 1500 microns or lower using the suction service port, the discharge service port after the check valve and the service port of the receiver (if applicable).

NOTE

When pulling a vacuum, the Schrader valves will unnecessarily restrict the openings, increasing the evacuation time. During the evacuation process it is recommended to remove the schrader valve cores with a Schrader valve core removal tool and draw the vacuum through the port on the removal tool.

4. If you cannot evacuate the system below 1500 microns, close the vacuum pump isolation valve and perform a rate-of-rise test by observing the standing pressure over time. If the pressure rises slowly (up to 200 microns in 15 minutes) it indicates moisture is in the system that still needs to be boiled off.

If the pressure rises rapidly up to atmospheric pressure (more than 50 microns per minute) it indicates a leak that wasn't detected during step #2. In this case troubleshoot the entire system for leaks and repair

them. Then begin the initial evacuation process again starting at step #3.

5. If no leaks are detected after the initial vacuum, release the vacuum and pressurize the system with 2-3 lb of dry nitrogen. Allow the system to stand for two hours with the dry nitrogen charge. This gives time for the nitrogen molecules to disperse in the system absorbing moisture.
6. After two hours, release the pressure. Then turn on the vacuum pump and evacuate the system a second time down to 1500 microns or less. Close the vacuum pump isolation valve and pressurize the system again with dry nitrogen and allow the system to stand for two hours as in step #5.
7. After two hours release the pressure. Turn on the vacuum pump and complete the process of evacuating the system, this time with a goal of achieving a 250 micron vacuum or less. Close the vacuum pump isolation valve. When you can hold the vacuum at 500 microns or lower for at least 2 hours with no significant rise in pressure, the system is ready to charge.
8. Replace the Schrader valve cores if you removed them during the evacuation steps. You may now introduce the refrigerant charge through the schrader valves.

2.7.4 Refrigerant Charging Procedures

CAUTION

POE oil is used in systems with R407C or R410A refrigerant. POE oil quickly absorbs moisture when exposed to air. High POE oil moisture levels react with refrigerant to form acid which results in system contamination. Keep the entire system sealed as much as possible and minimize exposure of the POE oil to outside air.

WARNING

If refrigerant gas is released in an enclosed area, it may accumulate in low areas and near the floor displacing available oxygen. If a major leak occurs, there is a risk of asphyxiation. In such case the area should be immediately evacuated and ventilated. Personnel should remain away from the area until it is determined to be safe.

NOTE

Refrigerant charging must be performed by a qualified air conditioning technician. STULZ recommends using the services of our Field Service Department to assist in start-up and commissioning.

We have assembled a highly qualified team of experienced industry professionals who provide expert start-up services anywhere in the world. They will ensure your equipment is correctly installed and is operating properly. This will help to ensure your unit provides years of trouble free service while operating at its highest efficiency. They will also enter the necessary Information for you on the Warranty Registration and Start-up Checklist and ensure it is filed with STULZ for your warranty protection.

2.7.4.1 Estimating Refrigerant Charge

When charging a system with R407C or R410A refrigerant it will be necessary to weigh in the refrigerant. Calculate the amount of refrigerant needed by adding the amount of refrigerant required for the A/C unit (shown in the A/C unit IOM provided separately) plus the refrigerant for the RCU (Table 5) plus the refrigerant piping (Table 6).

Table 5 may be used to estimate the amount of R407C or R410A refrigerant needed (in lb) to charge RCUs by model number.

The values shown in Table 5 are estimated weights. The final refrigerant charge weight depends on site-specific conditions.

Example: Estimate the amount of refrigerant required for a system using R407C refrigerant consisting of a 5 ton A/C unit connected with a 1/2" x 30 equivalent ft liquid line and 7/8" x 30 equivalent ft discharge line to a RCU-060 -30 °F condenser with flooded head pressure control and receiver.

$$\begin{aligned}
 \text{A/C Unit} &= 5.2 \text{ lb} \\
 + \text{RCU w/Flooded HP Control} &= 18.8 \text{ lb} \\
 + \text{1/2" Liquid Line- } 30 \times \frac{6.51}{100} &= 1.953 \text{ lb} \\
 + \text{7/8" Suction Line- } 30 \times \frac{0.57}{100} &= 0.171 \text{ lb} \\
 \hline
 = \text{Total Estimated Refrigerant Charge} &= 26.124 \text{ lb} \\
 \text{(Round off to the nearest lb)} &= 26 \text{ lb}
 \end{aligned}$$

Table 5. Weight of Refrigerant (lb/100 ft, Type L)

| Line Size O.D. | Liquid Line 105 °F | | Suction Line 40 °F | |
|----------------|--------------------|--------|--------------------|-------|
| | R407C | R410A | R407C | R410A |
| 1/2 | 6.51 | 5.88 | 0.17 | 0.22 |
| 5/8 | 10.46 | 9.44 | 0.27 | 0.36 |
| 7/8 | 21.73 | 19.62 | 0.57 | 0.74 |
| 1 1/8 | 37.04 | 33.44 | 0.97 | 1.26 |
| 1 3/8 | 56.43 | 50.95 | 1.48 | 1.93 |
| 1 5/8 | 79.87 | 72.11 | 2.09 | 2.72 |
| 2 1/8 | 175.32 | 158.29 | 4.59 | 5.98 |

Table 6. Standard Refrigerant Charge Weights

| RCU Model Number | R407C (lb per Unit) | | R410A (lb per Unit) | |
|------------------|---------------------|---------------------|---------------------|---------------------|
| | Fan Control | *Flooded HP Control | Fan Control | Flooded HP Control* |
| -012 | 1.1 | 10.9 | 1.1 | 10.0 |
| -018 | 1.1 | 10.9 | 1.1 | 10.0 |
| -024 | 1.1 | 10.9 | 1.1 | 10.0 |
| -032 | 1.6 | 11.4 | 1.6 | 10.5 |
| -040 | 1.6 | 11.4 | 1.6 | 10.5 |
| -042 | 3.5 | 18.8 | 3.6 | 17.5 |
| -048 | 3.5 | 18.8 | 3.6 | 17.5 |
| -060 | 3.5 | 18.8 | 3.6 | 17.5 |

* Includes Receiver

Ensure an adequate supply of refrigerant is available before beginning.

When charging a system using a blended refrigerant, maintaining the composition of the refrigerant is essential. To ensure correct composition, introduce the refrigerant (R407C or R410A) into the system in liquid rather than vapor form. Cylinders that do not have dip tubes should be inverted to allow only liquid refrigerant to charge the system. Keeping the temperature of the cylinder below 85 °F will help maintain the correct refrigerant composition while the cylinder is emptied.

INITIAL SYSTEM CHARGE

2.7.4.2 Introducing the Refrigerant Charge

Follow the steps below to charge systems with R407C and R410A refrigerant. The initial charge will be performed by introducing liquid refrigerant (R407C or R410A) to the discharge side of the compressor or an available liquid line port with the A/C unit turned Off.

1. Bleed air from hoses and break the vacuum by supplying liquid refrigerant (R407C or R410A) to the discharge port near the compressor until the pressure between the unit and the refrigerant cylinder is equalized. This initial charge allows the low pressure switch to "hold" enabling the compressor to operate throughout the process of charging the system.

FINE TUNING THE SYSTEM CHARGE

Once the initial charge is completed, additional refrigerant will need to be added (or removed) with the unit running until the superheat temperature can be maintained between 12–15 °F and sub-cooling can be maintained between 5–20 °F.

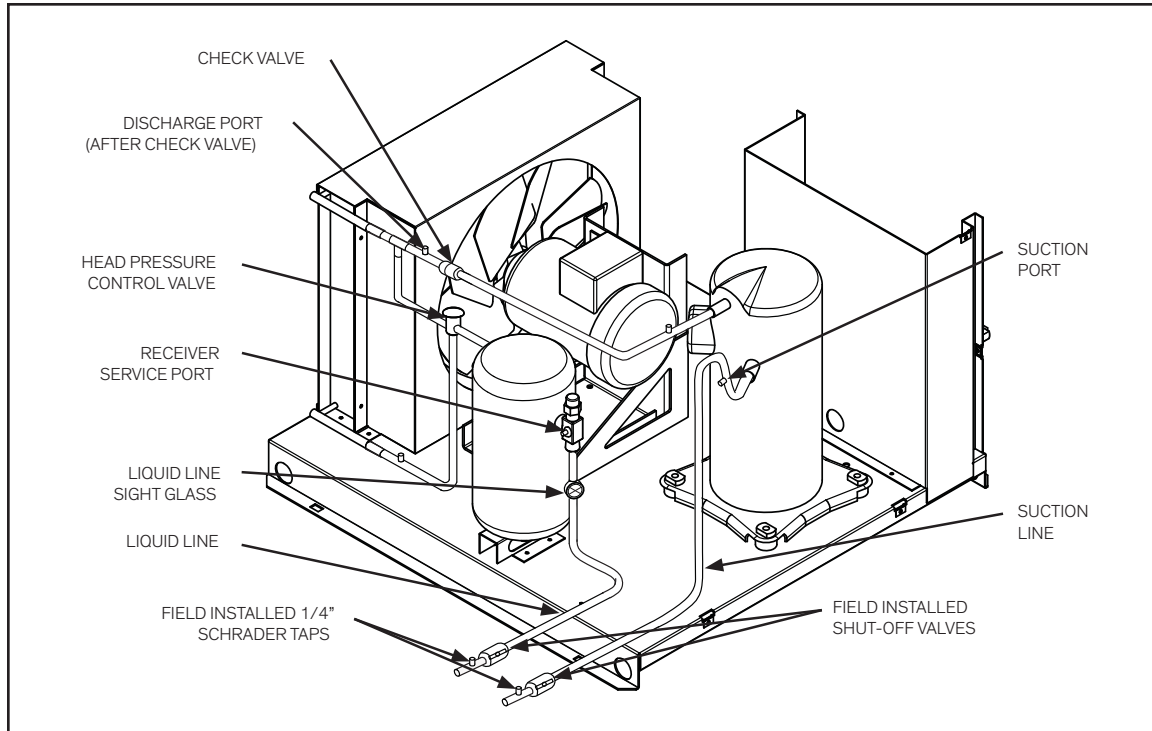

Figure 7. Refrigerant Charging Ports (RCU-O)

CAUTION

An adequate heat load must be supplied to ensure a proper charge.

2. Disconnect the refrigerant cylinder from the discharge side of the compressor and connect it to the suction side.
3. Referring to Section 3.2, start the A/C system and use the system controller to lower the room temperature setpoint 3–5 °F below actual room temperature thus ensuring the compressor remains on as the unit is charged.

When fine tuning the charge during low ambient conditions it will be necessary to restrict the airflow across the condenser coil to raise the pressure. The fan closest to the header must be running. When fine tuning the charge, ensure the pressures are correct for the type of refrigerant used. Refer to the tables in section 2.7.5 for the operating temperatures and pressures for the type of refrigerant used in your system.

4. Partially block the intake air to the condenser until a constant discharge pressure can be obtained.
 - a. R407C Refrigerant- Allow the discharge pressure to rise to 260–315 psig and hold it constant.
 - b. R410A Refrigerant- Allow the discharge pressure to rise to 445–480 psig and hold it constant.

5. Slowly meter liquid refrigerant through the suction side while watching the pressure gauges and monitoring superheat and sub-cooling temperatures.

CAUTION

Add liquid refrigerant slowly to prevent the refrigerant oil from “washing out” of the compressor.

6. Take a superheat temperature reading near the feeler bulb from the thermostatic expansion valve with the temperature measuring device being well insulated. The ideal superheat temperature is 12–15 °F. Maximum allowable superheat temperature is 20 °F.
7. While monitoring the pressure, take a sub-cooling temperature reading on the output side of the condenser. The sub-cooling temperature should be 5–20 °F.
8. If necessary, (slowly) add liquid refrigerant to the suction side to achieve the sub-cooling temperature.
9. If the unit has hot gas reheat (optional), the previous steps are still followed except the hot gas reheat valve must be open to allow refrigerant to flow into the reheat coil to obtain the proper amount of refrigerant charge. This can be done by using the system controller to enable a call for dehumidification (lower the humidity setpoint). This process may need to be repeated several times. After cycling the system through the hot gas reheat cycle,

recheck the superheat and sub-cooling temperatures with the system only in the cooling mode.

CAUTION 

Remove the blockage from the air intake of the condenser.

- Fill out the applicable sections of Warranty Registration and Start-Up Checklist.

2.7.4.3 -30 °F Flooded Head Pressure Control

For units utilizing flooded head pressure control, a receiver is used to store the refrigerant during the time the condenser is not utilizing the extra refrigerant charge.

- For -30 systems, additional refrigerant is required so that there is an adequate amount of refrigerant to effectively “flood” the condenser coil during low ambient operation. When estimating the amount of refrigerant required be sure to use the “Flooded HP Control” charge weight in Table 6. When breaking the vacuum with the initial refrigerant charge, it is desirable to install as much of the estimated charge as possible with the compressor remaining off. To accomplish this, introduce liquid refrigerant directly into the service port of the receiver (see Figure 8) and then liquid refrigerant into the discharge line service port. (Do not introduce more refrigerant than the total estimated system charge).

NOTE

It is important not to exceed 80% of the total condenser and receiver volume to allow room for expansion.

- Give the unit a call for cooling to turn on the compressor. With the compressor running, any remaining amount of the estimated charge can be introduced into the suction port of the compressor.
- A refrigerant level sight glass may be located on the side of the receiver to assist the service technician in charging the air conditioning system. The proper charge can be fine tuned/verified by viewing the level of refrigerant in the receiver while the unit is running at an elevated discharge pressure.
- Block off the air intake to the condenser and allow the discharge pressure to rise to 445 psig (410A) or 325 psig (407C) and hold it constant for a minimum of 10 minutes.
- When the unit is properly charged, the receiver sight glass will show half full of liquid while running at the elevated discharge pressure.
- Verify superheat and sub-cooling temperatures are within operating parameters.

CAUTION 

Remove the blockage to the air intake of the condenser.

- Fill out the applicable sections of the Warranty Registration and Start-Up Checklist.

2.7.5 Refrigerant Characteristics

2.7.5.1 Pressure/Temperature Settings

Table 7 and Table 8 are provided to assist with the normal settings of the system for R407C and R410A refrigerant. Where applicable, minimum and maximum settings are given along with normal operating pressures.

Table 7. Pressure/Temperature Settings for R407C

| Pressure/Temperature Settings For R407C | | | |
|---|--------|--------------|------|
| | Normal | Min. | Max. |
| Sub-cooling °F | 10 | 5 | 20 |
| Superheat °F | 15 | 10 | 20 |
| Design Condensing Temp. @ 95 °F | 125 | 105 | 140 |
| Suction Pressure (psig)- R407C | 70 | 55 | 85 |
| | Opens | Closes | |
| Low Pressure Switch (psig)- R407C | 10 | 32 | |
| High Pressure Switch (psig)- R407C | 410 | Manual Reset | |

NOTE

The operating pressures for R410A refrigerant are significantly higher than R407C.

Table 8. Pressure/Temperature Settings for R410A

| Pressure/Temperature Settings For R410A | | | |
|---|--------|--------------|------|
| | Normal | Min. | Max. |
| Sub-cooling °F | 10 | 5 | 20 |
| Superheat °F | 15 | 10 | 20 |
| Design Condensing Temp. @ 95 °F | 125 | 105 | 140 |
| Suction Pressure (psig) - R410A | 130 | 105 | 155 |
| | Opens | Closes | |
| Low Pressure Switch (psig) - R410A | 65 | 105 | |
| High Pressure Switch (psig) - R410A | 630 | Manual Reset | |

2.7.5.2 Saturated Refrigerant Pressure Tables

The refrigerant vapor pressure tables in Table 9 are provided for reference for R407C and R410A refrigerant.

Table 9. Refrigerant Vapor Tables

| R410A Refrigerant | | R407C Refrigerant | |
|--|-----------------|--|-----------------|
| Temp. (°F) | Pressure (psig) | Temp. (°F) | Pressure (psig) |
| Saturated Evaporating Temperature | | Saturated Evaporating Temperature | |
| 20 | 78.4 | 20 | 37.9 |
| 22 | 81.9 | 22 | 40.1 |
| 24 | 85.5 | 24 | 42.3 |
| 26 | 89.2 | 26 | 44.7 |
| 28 | 93.1 | 28 | 47.1 |
| 30 | 97.0 | 30 | 49.6 |
| 32 | 101 | 32 | 52.1 |
| 34 | 105 | 34 | 54.8 |
| 36 | 109 | 36 | 57.5 |
| 38 | 114 | 38 | 60.3 |
| 40 | 118 | 40 | 63.2 |
| 42 | 123 | 42 | 66.1 |
| 44 | 128 | 44 | 69.2 |
| 46 | 133 | 46 | 72.3 |
| 48 | 137 | 48 | 75.5 |
| 50 | 143 | 50 | 78.8 |
| Saturated Condensing Temperature | | Saturated Condensing Temperature | |
| 55 | 155 | 95 | 209 |
| 60 | 170 | 100 | 225 |
| 65 | 185 | 105 | 242 |
| 70 | 201 | 110 | 260 |
| 75 | 218 | 115 | 279 |
| 80 | 236 | 120 | 298 |
| 85 | 255 | 125 | 319 |
| 90 | 274 | 130 | 341 |
| 95 | 295 | 135 | 363 |
| 100 | 318 | 140 | 387 |
| 105 | 341 | | |
| 110 | 365 | | |
| 115 | 391 | | |
| 120 | 418 | | |
| 125 | 446 | | |
| 130 | 477 | | |
| 135 | 508 | | |
| 140 | 541 | | |

Dew Point
(Saturated Vapor)

Bubble Point
(Saturated Vapor)

R407C Pressure Switch Settings:

The high-pressure switch opens at 410 psig and has a manual reset. The low-pressure switch opens at 10 psig (± 4) and closes at 32 psig (± 5) and has an automatic reset.

R410A Pressure Switch Settings:

The high-pressure switch opens at 630 psig and has a manual reset. The low-pressure switch opens at 65 psig (± 10) and closes at 105 psig (± 10) and has an automatic reset.

2.8.2 Head Pressure Controls

2.8.2.1 Condenser Fan Cycling

The condenser fan cycling switch senses refrigerant discharge pressure and turns on the condenser fan as required to maintain allowable condenser pressures. This is a high-pressure differential control switch with SPST contacts and an automatic reset. The switch activates the condenser fan contactor, cooling the condenser to maintain the condensing temperature when the discharge pressure rises.

R407C Refrigerant:

Factory setting: The fan cycling switch contacts are set to close on a pressure rise to 320 psig and open at 250 psig. Set point range is 170 to 375 psig. The differential is set at 70 psi and is adjustable.

R410A Refrigerant:

Factory setting: The fan cycling switch contacts are set to close on a pressure rise to 440 psig and open at 330 psig. Set point range is 275 to 600 psig. The differential is set at 110 psi and is adjustable.

2.8.2.2 Condenser Fan Speed

STULZ RCU units may be equipped with variable speed condenser fan motor control to maintain head pressure control. The fan speed control is a continual modulation of the motor's speed. The condenser fan speed controller monitors the refrigerant discharge pressure and varies the condenser fan speed as required to maintain allowable condenser pressures. The fan speed controller is set to maintain condensing temperature at 125 °F and requires no adjustment.

2.8.2.3 Flooded Head Pressure Control

Flooded head pressure control is designed to maintain head pressure during low ambient temperature conditions. A head pressure control valve and a receiver is provided in the refrigeration circuit to back up liquid refrigerant into the condenser coil.

When the receiver pressure drops the valve diverts discharge gas away from the condenser. The liquid from the condenser is restricted, which allows liquid to flow back up in the condenser. Flooding the condenser reduces the area available for heat transfer thus raising the condensing

2.8 Settings and Adjustments

2.8.1 High/Low Pressure Limit Switches

STULZ RCU units are equipped with hermetically sealed high-pressure and low-pressure switches. These switches are preset by the manufacturer and cannot be adjusted. The high pressure switch will open to disengage power to the compressor contactor if the discharge pressure rises above a specific pressure. The low pressure switch will open to disengage power to the compressor contactor if suction pressure drops below a specific pressure. The system controller should ignore the absence of this signal during the cold start delay period after starting of a compressor.

pressure. As the pressure increases, the valve diverts the discharge gas to the condenser, which will allow liquid flow from the condenser to the receiver.

When using this method of head pressure regulation there must be enough refrigerant in the system to ensure adequate charge at the lowest expected ambient temperature that the system will be operating.

A receiver is used to store the refrigerant during the time the condenser is not using the extra refrigerant charge. The head pressure control valve does not begin to allow refrigerant to pass to the receiver until the discharge pressure is at least 225 psig for R407C; 290 psig for R410A. This valve requires no adjustment.

RCU units utilize either R407C or R410A refrigerant. Refrigerant charging pressures vary depending on the type of refrigerant used in the unit. Tables are provided in Section 2.7.5 on page 14 showing the temperature/pressure characteristics for R407C and R410A refrigerant. Before charging, check the unit nameplate to confirm the type of refrigerant to use.

2.8.3 Hot Gas Bypass

A full floating hot gas bypass system may be provided as an option for capacity control and freeze protection. The hot gas bypass valve allows refrigerant to flow from the discharge line directly to the suction line. This provides freeze protection for the evaporator coil by limiting the minimum refrigerant pressure, preventing the surface temperature of the evaporator coil from dropping below 32 °F.

The hot gas (discharge) regulating valve has a normal suction pressure control setting of:

- R407C - 55 ±2 psig
- R410A - 105 ±2 psig

This is read from the suction (low) side of the compressor as it operates in full hot gas bypass operation. The valve is factory set and no adjustment should be necessary. If adjustment is required, remove the adjustment cap from the valve. Using a 5/16 inch Allen wrench, turn clockwise to increase pressure or counterclockwise to lower pressure.

CAUTION

Do not exceed 20 °F superheat. Exceeding this temperature may cause failure of the compressor.

To prevent overheating the compressor, a small amount of liquid refrigerant passes through the quench valve and mixes with the hot gas entering the compressor, maintaining normal compressor suction pressure and temperature.

The normal control setting for the quench valve is 20 °F superheat (when there is no call for cooling). The valve is factory set and no adjustment should be necessary. If adjustment is required, remove the adjustment cap from the valve. Turn the adjusting stem clockwise to increase the superheat and counterclockwise to decrease the superheat.

3.0 COMMISSIONING AND DECOMMISSIONING

3.1 Operation

For new installations, ensure the unit is ready to operate by going through the Checklist for Completed Installation, located in Appendix A, prior to start-up.

NOTE

A Warranty Registration and Start-Up Checklist is provided with the unit data package. It should be completed during start-up and sent to STULZ. This checklist should be used as a guideline for items that need to be confirmed during start-up.

Start-up must be performed by a journeyman, refrigeration mechanic or an air conditioning technician.

3.2 Step by Step Start-Up Instructions

CAUTION 

Prior to initial start-up (only when main power has been disconnected for 12 hours or longer), allow at least ten 10 minutes, (two hours is recommended), with main power reconnected. This will allow sufficient time for the crankcase heaters to evaporate any liquid that may have migrated to the compressor crankcase. When this procedure is completed, the unit is ready to be run.

1. Replace all equipment removed prior to performing start-up checks.
2. Apply power to the RCU system at the main power disconnect switch.

NOTE

The compressor may have a time delay on start-up.

The refrigeration circuit must be tested at start-up. Refer to the separate controller operation instructions sent with your unit in the data package.

3. Test cooling operation by adjusting the temperature setpoint at the system controller. The compressor should come on and the suction line should gradually drop in temperature.

3.3 Operational Description

1. Compressor starts; condenser fan starts.

NOTE

RCUs equipped with condenser fan cycling or condenser fan speed control, have a delay after the compressor starts for the minimum pressure to be reached to start the fan motor.

2. Refrigerant flowing to the RCU unit in the form of a low pressure gas, enters the compressor where it is compressed into a high pressure gas.
3. The refrigerant then flows to the condenser coil. The high temperature, high-pressure gas from the compressor is cooled and condensed by the flow of air through the condenser coil and is changed into a high-pressure liquid.
4. For cold weather applications using flooded head pressure control and/or full floating hot gas bypass, the liquid refrigerant flows to a receiver. The receiver acts as a storage tank for the liquid refrigerant that is not in circulation.
5. The liquid refrigerant flows through a sight glass. This device indicates the presence of air and moisture and gives a visual indication of the state of the refrigerant in the system.
6. The high pressure liquid refrigerant then flows to the air conditioner. The refrigerant passes through a metering device before entering the evaporator coil where it removes heat and evaporates into a gas.
7. The refrigerant gas is then drawn back to the compressor and the cycle is repeated.
8. A pump down cycle prevents liquid refrigerant from condensing in the evaporator during off cycles.

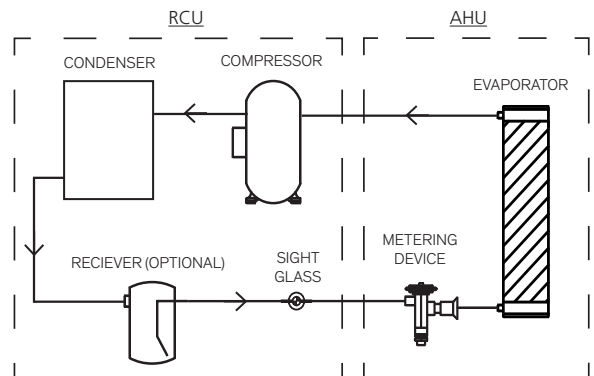

Figure 8. Refrigeration Cycle

3.4 Decommissioning the Unit

Personnel performing the decommissioning must be completely familiar with the unit before starting. Best practice requires all refrigerants be recovered safely; see section 3.4.1 for guidelines. Prior to recovery, an oil and refrigerant sample should be taken in case analysis is required prior to re-use of the reclaimed refrigerant. Electrical power must be available before decommissioning is started.

Follow these decommissioning guidelines:

1. Become familiar with the equipment and its operation.
2. Isolate the system electrically.
3. Before attempting the procedure ensure that:
 - Mechanical handling equipment is available, if required, for handling refrigerant cylinders
 - All required personal protective equipment is available and used correctly
 - The recovery process is supervised at all times by competent personnel
 - Recovery equipment and cylinders conform to the appropriate standards
4. Pump down the refrigerant system, if possible.
5. If a vacuum is not possible, make a manifold so that refrigerant can be removed from various parts of the system.
6. Place the cylinder receiving the refrigerant on the scale before starting recovery.
7. Start the recovery machine and operate in accordance with manufacturer's instructions.
8. Do not overfill cylinders. (They should contain no more than 80 % volume liquid charge).
9. Do not exceed the maximum working pressure of the cylinder, even temporarily.
10. When the cylinders have been filled correctly and the process completed, make sure that the cylinders and the equipment are removed from site promptly and all isolation valves on the equipment are closed off.
11. Recovered refrigerant must not be charged into another refrigeration system unless it has been cleaned and checked.

3.4.1 Recovering Refrigerant

When removing refrigerant from a system, either for servicing or decommissioning, best practice is to remove all refrigerants safely. Use the following recommended guidelines:

- When transferring refrigerant into cylinders, ensure that only appropriate refrigerant recovery cylinders are employed. Ensure that the correct number of cylinders for holding the total system charge are available and that all cylinders to be used are designated for the recovered refrigerant and labelled for that refrigerant (i.e., special cylinders for the recovery of refrigerant). Cylinders must be complete with pressure relief valve and associated shut-off valves in good working order. Empty recovery cylinders must be evacuated and, if possible, cooled before recovery occurs.
- Recovery equipment must be in good working order with a set of instructions concerning the equipment at hand, and the equipment must be suitable for recovering flammable refrigerants. In addition, a set of calibrated weighing scales must be available and in good working order. Hoses must be complete with leak-free disconnect couplings and in good condition. Before using the recovery machine, check that it is in satisfactory working order, has been properly maintained and that any associated electrical components are sealed to prevent ignition in the event of a refrigerant release. Consult manufacturer if in doubt.
- Recovered refrigerant must be returned to the refrigerant supplier in the correct recovery cylinder, and the relevant Waste Transfer Note arranged. Do not mix refrigerants in recovery units and especially not in cylinders.
- If compressors or compressor oils are to be removed, ensure they have been evacuated to an acceptable level to make certain flammable refrigerant does not remain within the lubricant. The evacuation process must be carried out prior to returning the compressor to the suppliers. Only electric heating of the compressor body may be employed to accelerate this process. When oil is drained from a system, it must be carried out safely.

3.4.2 Labeling Decommissioned Equipment

Equipment must be labelled stating that it has been decommissioned and emptied of refrigerant. The label must be dated and signed. Ensure that there are labels on the equipment stating the equipment contains flammable refrigerant.

4.0 MAINTENANCE/REPAIRS

4.1 Periodic General Maintenance

Systematic, periodic general maintenance of the remote condensing unit is recommended for optimum system performance. General maintenance should include, but is not limited to the following: tightening electrical connections, cleaning the interior of the unit, inspecting the unit's components visually, checking the level of refrigerant and ensuring no moisture is in the refrigerant.

Use copies of the Periodic General Maintenance Checklist in this manual (see Appendix A) to record periodic general maintenance inspections. For assistance, contact STULZ Product Support. Ensure adherence to all safety statements while performing any type of maintenance.

WARNING

Turn off power to the unit at the main power disconnect switch unless you are performing tests that require power. With power and controls energized, the unit could begin operating automatically at any time.

Hazardous voltage will still be present even with the unit turned off at the controller. To isolate the unit for maintenance, turn off power at the main power disconnect switch.

Always disconnect main power prior to performing any service or repairs. To prevent personal injury, stay clear of rotating components because automatic controls may start them unexpectedly.

This unit employs high voltage equipment with rotating components. Exercise extreme care to avoid accidents and ensure proper operation.

4.1.1 General

Maintenance access to the remote condensing unit is through the removable panel on top of the unit. Examine the areas around the air inlet and outlet grills, fans, motors and coils. Use a vacuum cleaner with a soft bristle brush to clean dirt from components. Clean the coil of all debris that will inhibit airflow. This can be done with a soft brush and compressed air or with a commercial coil cleaner. Check for bent or damaged coil fins and repair as necessary. On outdoor units do not permit snow to accumulate on or around the RCU in the winter. Check all refrigerant lines and capillaries for vibration isolation and support as necessary. Check all refrigerant and lines for signs of leaks.

- Examine all wiring for signs of chafing, loose connections or other obvious damage. (Quarterly)

- Examine brackets, motor mounts and hardware for loose or missing parts or other damage. (Quarterly)
- Clean accumulations of dust and dirt from all interior and exterior surfaces. (Quarterly)

CAUTION

The compressor crank case heater is energized as long as power is applied to the unit. If the service switch is turned off for long periods do not attempt to start a condensing unit until two hours after applying power. This allows enough time for all liquid refrigerant to be driven out of the compressor. This is especially important at low ambient conditions.

4.1.2 Compressor

The refrigerant compressor and its drive motor are hermetically sealed. The compressor crankcase has a lifetime supply of oil and the drive motor has permanently lubricated sealed bearings. Check the refrigerant for moisture and discoloration using the sight glass while the unit is running. Check the refrigerant charge by measuring the superheat and sub-cooling temperatures. If low on charge, check for refrigerant leaks.

This equipment should be serviced and repaired by a journeyman or a qualified refrigeration technician only.

WARNING

Fluorophosgene, a deadly, poisonous gas, is generated when refrigerant is exposed to flame. Always ensure adequate ventilation during refrigeration repairs.

Always recover all refrigerant prior to any system repairs, failure to do so may result in system over pressurization and rupture.

4.2 Troubleshooting

WARNING

Turn off all power to the unit before conducting any troubleshooting procedures, unless the procedure specifically requires the system to operate. For troubleshooting purposes, the system may be operated with the access panel open by using a pair of channel lock pliers to turn the shaft of the main power disconnect switch to the "On" position. When the switch is turned on, high voltage will be present inside the cabinet. Keep hands, clothing and tools clear of the electrical terminals and rotating components. Ensure your footing is stable at all times.

| SYMPTOM | PROBABLE CAUSE | RECOMMENDATION |
|---|---|---|
| Control is Erratic | Wiring improperly connected or broken. | Check wiring against electrical drawing. |
| Unit Fails to Start | a. Incorrect phasing or voltage. | Correct phase or voltage input. |
| | b. Power failure. | Check power source, power inlet and fuses. Check control cables and connections. |
| | c. Overload protection tripped. | Check for cause of overload and re-set circuit breaker(s) or motor starter protector(s). |
| Condenser Head Pressure Too High | a. Non-condensable gas or air in system. | Recover system, evacuate per Section 2.7.3 and recharge. Install new drier/strainer. |
| | b. Low condenser airflow (indicated by excessive warm air leaving the condenser fan). | Open air passages. Clean coil. Check condenser fan(s). |
| | c. Overcharge of refrigerant. | Reclaim excess refrigerant from system. |
| | d. Condenser fan not operating. | <ol style="list-style-type: none"> 1. Check main voltage power source to unit. 2. Check fan motor starter protector, contactor, fan cycling switch or fan speed controller. 3. Check pressure/temperature operating switches and motor. Replace as needed. |
| | e. Condenser pressure regulating valve setting too high. | Adjust to obtain correct pressure. |
| Condenser Head Pressure Too Low | a. Loss of refrigerant (indicated by high superheat, low sub-cooling temperature and low suction pressure). | Locate and repair leak. Recharge system. |
| | b. Condenser fan controls not set properly. | Adjust or repair controls. |
| | c. Control pressure set too low. | R407C- Readjust to 320 psig. R410A- Readjust to 440 psig. |
| Suction Pressure Too Low | a. Loss of refrigerant (excessive bubbles in sight glass). | Locate leak and repair. Recharge system. |
| | b. Expansion valve stuck or obstructed (short cycle or continuous running). | Remove and clean or replace valve. |
| | c. Clogged drier/strainer (feels cold). | Replace with new drier/strainer. |
| | d. Dirty air filters. | Clean/replace filters on AHU. |

| SYMPTOM | PROBABLE CAUSE | RECOMMENDATION |
|-------------------------------|---|---|
| Noisy Compressor | a. Expansion valve stuck in open position (abnormally cold suction line). | Check operation of the expansion valve and superheat. |
| | b. Worn or scarred compressor bearings. | Replace compressor. |
| | c. Broken compressor valve (compressor knocking, suction pressure rises faster than 2 lb/min after shutdown). | Replace compressor. |
| | d. Liquid slugging. | 1. Ensure expansion valve is not stuck in open position. 2. System overcharged. Reclaim excess refrigerant. |
| | e. Scroll compressor not properly phased. | Phase correctly at main power source. Do not rewire compressor. |
| Blower Fails to Start | a. Power failure. | Check main voltage power source input cable. |
| | b. Control transformer circuit breaker tripped. | Check for short circuit or ground fault; if none, reset circuit breaker. |
| | c. Defective contactor. | Repair or replace. |
| | d. Motor starter protector tripped. | Reset motor starter protector and check amperage of motor. Compare to setting of motor protector and adjust FLA. |
| Head Pressure Too High | a. Low condenser airflow (indicated by excessive warm air leaving the condenser fan). | Open air passages. Clean coil. Check condenser fan(s). |
| | b. Air or other non-condensable gas in system. | Reclaim system and recharge. Install a new drier strainer. |
| | c. Overcharge of refrigerant. | Reclaim excess refrigerant from system. |
| | d. Condenser fan not on. | 1. Check main voltage power source to the unit. 2. Check fan motor starter protector, contactor, fan cycling switch or fan speed controller. |

| SYMPTOM | PROBABLE CAUSE | RECOMMENDATION |
|----------------------------------|--|---|
| Suction Pressure too Low | a. Expansion valve not opening fully (indicated by abnormally cold suction line). | Open air passages. Clean coil. Check condenser fan(s). |
| | b. Low charge, flash gas in liquid line (indicated by high superheat, low sub-cooling temperature and low suction pressure). | Reclaim system and recharge. Install a new drier strainer. |
| | c. Clogged drier/strainer (feels cool to the touch). | Reclaim excess refrigerant from system. |
| | d. Obstructed expansion valve (indicated by loss of capacity). | 1. Check main voltage power source to the unit. 2. Check fan motor starter protector, contactor, fan cycling switch or fan speed controller. |
| Compressor Fails to Start | a. Temperature setpoint too high. | Adjust to desired temperature. |
| | b. Compressor internal overload protector is open. | Check compressor for short circuit or ground. |
| | c. Complete loss of refrigerant charge (low pressure safety switch). | Locate and repair leak. Recharge system. |
| | d. Condenser pressure too high (high pressure safety switch). | Check condenser for obstructions. Re-set high pressure switch. |
| | e. Minimum off time has not expired. | Wait for time to expire. |
| System Short of Capacity | a. Low refrigerant (indicated by bubbles in sight glass). | Check for leaks. Repair and recharge system. |
| | b. Expansion valve stuck or obstructed (short cycling or continuous running). | Remove valve and clear obstruction or replace valve. |
| | c. Reduced airflow. | Check belt tension, filters and clear evaporator coil of debris. |
| Compressor Short Cycles | a. Low line voltage causing compressor to overheat. | Check power source for cause of low line voltage. |
| | b. Dirty or iced over evaporator coil. | Defrost and clean evaporator/heat exchanger. |
| | c. Reduced airflow (when applicable). | Check filter and belt tension. |
| | d. Lack of refrigerant. | Check for leak. Repair and recharge system. |
| | e. Short cycling of conditioned air. | Insufficient heat load. Increase heat load. |
| | f. Remote temperature sensor is improperly located. | Check for supply registers that may be too close to thermostat. Relocate if necessary. |

4.3 Field Service

It may be necessary to perform repairs on the refrigeration system. If field repairs are necessary, the following procedures apply:

NOTE

Do not attempt to make repairs without the proper tools.

4.3.1 Leak Detection

Several methods can be used to detect a leak in the refrigeration system. The most modern and easiest method is to use an electronic leak detector. Follow the manufacturer's directions and any leak can be quickly located. A second method is to use soap bubbles. Apply a solution of soapy water with a brush or sponge to the joints and connections in the refrigeration lines. A leak in the lines will cause bubbles to form.

4.3.2 Leak Repair

When a leak is located, properly reclaim the remaining refrigerant charge before attempting repairs. Adjacent piping must be thoroughly cleaned by removing all paint, dirt and oily film. Use wire brush, sandcloth or sandpaper and wipe the area with clean, dry cloths. Protect nearby parts from heat damage by wrapping with water-soaked cloths

4.3.3 Refrigerant Piping

When replacing refrigeration components within the cabinet of the unit, the following consumable materials are recommended:

When brazing copper-to-copper connections (piping liquid line or suction line), use a phosphorus copper brazing alloy with 15% silver. General purpose silver brazing alloy with 45% silver is to be used for copper-to-brass or copper-to steel.

Wrap wet rags around the pipes between the areas to be soldered and any nearby refrigeration components to keep excessive heat from traveling through the pipe and causing damage.

When component replacement is complete, remove all traces of flux. After any repair, pressure check the system to check for leaks prior to recharging the system.

4.3.4 General Common Repairs/Component Replacement

4.3.4.1 Compressor Failure

The compressor is the most important component of the RCU. Numerous safety devices are provided to protect the compressor from failing.

If a compressor failure has occurred, determine whether it is an electrical or a mechanical failure. An electrical failure will be indicated by the distinct pungent odor once the system has been opened. If a burnout has occurred, the oil will be black and acidic. A mechanical failure will have no burned odor and the motor will attempt to run, an abnormal or excessive noise may be present.

An analysis of the oil is the only way to determine the proper procedure for cleaning the refrigerant system. Acid test kits are available from several manufacturers for measuring the acid level in the oil. These are capable of making accurate acid measurements, but if they are not available, a check of the oil by sight and smell can give a quick indication if contamination remains in the system.

CAUTION

Avoid touching or contacting the gas and oil with exposed skin. Severe burns will result. Use long rubber gloves in handling contaminated parts.

All electrical connections should be checked to ensure they are tight and properly made. Check all circuit breakers, contactors and wiring. The contactors should be examined and replaced if contacts are worn or pitted.

If there is acid in the oil, there has been an electrical failure which has caused the compressor motor to burn out. The acid diffuses throughout the refrigeration system and must be removed by using a burnout filter kit before a new compressor is placed in service. Not only must the compressor be replaced, but also the entire refrigeration circuit must be cleaned of the harmful contaminants left by the burnout. See Section 4.3.4.3 (Burn-Out/Acidic Cleanup) for the proper cleaning procedure.

CAUTION

Damage to a replacement compressor caused by improper system cleaning constitutes abuse under the terms of the warranty. This will void the compressor warranty. Always consult the factory prior to replacing the compressor.

If there is no acid in the oil, there has been a mechanical failure. See Section 4.3.4.2 (Standard Cleanout) for the proper cleaning procedure.

CAUTION

POE oil is used in systems with R407C refrigerant. If a replacement compressor is provided, ensure that it is filled with POE oil before installing.

4.3.4.2 Standard Cleanout Procedure

CAUTION

Avoid touching or contacting the gas and oil with exposed skin. Severe burns will result. Use long rubber gloves in handling contaminated parts.

NOTE

Cleaning operations must be performed by a journeyman, refrigeration mechanic, or air conditioning technician.

1. Turn off power to the unit at the main power disconnect switch.
2. Remove the old compressor and install the new compressor.
3. Remove the liquid line drier and install an oversized liquid line filter-drier (one size larger than the normal selection size).
4. Evacuate the system according to standard procedures. Normally, this will include the use of a high-vacuum pump and a low-vacuum micron gauge for measuring the vacuum obtained.
5. Recharge the system.
6. Turn on the power at the main power disconnect switch and start the system.

4.3.4.3 Burn-Out/Acidic Cleanup Procedure

NOTE

Cleaning operations must be performed by a journeyman, refrigeration mechanic, or air conditioning technician.

1. These systems should be cleaned using the suction line filter-drier method.
2. Turn off power to the unit at the main power disconnect switch.
3. Remove the burned-out compressor and install the new compressor.
4. Install a suction line filter-drier designed for acid removal.
5. Remove the liquid line drier and install an oversized liquid line filter-drier (one size larger than the normal selection size).
6. Check the expansion valve, sight glass and other controls to see if cleaning or replacement is required.

7. Evacuate the system according to standard procedures. Normally, this will include the use of a high-vacuum pump and a low-vacuum micron gauge for measuring the vacuum obtained.
8. Recharge the system through the access valve on the suction line filter-drier.
9. Turn on power at the main power disconnect switch and start the system.
10. The permanently installed suction line filter-drier permits small-system cleanup to be completed in one service call. The pressure drop across the suction line filter-drier should be measured during the first hour of operation. If the pressure drop becomes excessive, the suction line filter-drier should be replaced (See Sporlan Bulletin 40-10, for maximum recommended pressure drop (PSI) for suction line filter drier).
11. In 24 hours, take an oil sample. Observe the color and test for acidity. If the oil is dirty or acidic, replace the suction line filter-drier.
12. In two weeks, examine oil to determine if another suction line filter-drier change is necessary.

4.3.4.4 Blower Belt Tensioning and Speed Adjustment

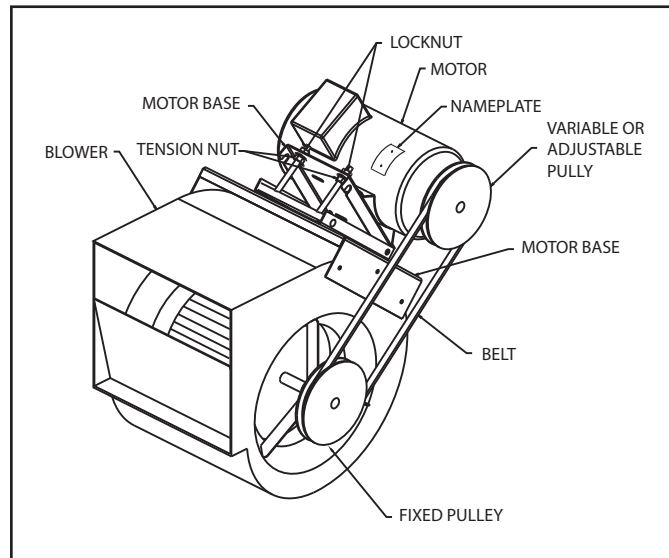

Figure 9. Belt Drive Blower

Systems with belt drive blowers (see Figure 9) are supplied with adjustable sheaves to change the blower speed and adjustable motor bases for belt tensioning. Perform the following procedure to change the blower speed.

1. Turn the system off.
2. Turn off all power to the unit at the non-fused service switch (RCU-O); use a lock-out/tag-out procedure. For

RCU-I, disconnect power to the unit at its main power disconnect switch.

3. Remove the blower belt(s).
4. Loosen the set screw in the side of the sheave with an Allen wrench.
5. Remove the sheave key.
6. Adjust the blower speed by closing the sheave one half turn to increase speed or opening the sheave one half turn to decrease speed.
7. Replace the sheave key and tighten set screw.
8. Proper belt tension is achieved when the belt has a deflection of 1/2 in. per foot of span between the blower and motor pulleys, with a firm pressure placed on the side of the blower belt. Adjust the blower belt tension by raising (to tighten) or lowering (to loosen) the nuts on the adjustment rods of the motor base.

CAUTION 

If the belt tension is too tight, it will cause premature blower and/or motor bearing failure. If the belt is too loose, the belt will slip and cause belt squeals and eventual belt failure.

9. Restore power to the system.
10. Check the current draw on the blower motor to make sure it does not exceed the nameplate rating of the motor.
11. If current draw exceeds the nameplate rating of the motor, repeat steps 1 through 10 to decrease blower speed. If the motor pulls too much current, slow the blower down by opening the adjustable sheave one half turn at a time until the motor current is at or below the nameplate FLA.
12. Check the motor overload on the blower starter to confirm its setting is correct for the FLA of the motor.

5.0 PRODUCT SUPPORT

STULZ provides its customers with Product Support which not only provides technical support and parts but the following additional services, as requested:

- Performance Evaluations
- Start-up Assistance
- Training

STULZ recommends using the services of our Field Service Department to perform start-up and commissioning. They will ensure your equipment is correctly installed and operating properly. This will help to ensure your unit provides years of trouble free service while operating at its highest efficiency.

5.1 Technical Support

The STULZ Technical Support Department is dedicated to the prompt reply and solution to any problem encountered with a unit. Should a problem develop that cannot be resolved using this manual, you may call (888) 529-1266 Monday through Friday from 8:00 a.m. to 5:00 p.m. EST. If a problem occurs after business hours, provide your name and telephone number. One of our service technicians will return your call.

When calling to obtain support, it is important to have the following information readily available, (information is found on the unit's nameplate):

- Unit Serial Number
- Unit Model Number
- STULZ Sales Order Number
- Description of Problem

5.2 Obtaining Warranty Parts

Warranty inquiries are to be made through the Technical Support Department at (888) 529-1266 Monday through Friday from 8:00 a.m. to 5:00 p.m. EST. A service technician at STULZ will assist in troubleshooting the system over the telephone with a field service technician to determine the defect of the part. If it is determined that the part may be defective a replacement part will be sent via UPS ground. If the customer requests that warranty part(s) be sent by any other method than UPS ground the customer is responsible for the shipping charges. If you do not have established credit with STULZ you must give a freight carrier account number.

A written (or faxed) purchase order is required on warranty parts and must be received prior to 2:00 p.m. for same day shipment. The purchase order must contain the following items:

- Purchase Order Number
- Date of Order
- STULZ Stated Part Price
- Customer Billing Address
- Shipping Address
- Customer's Telephone and Fax Numbers
- Contact Name
- Unit Model No. and Serial No.

The customer is responsible for the shipping cost incurred for returning the defective part(s) back to STULZ. Return of defective part(s) must be within 30 days at which time an evaluation of the part(s) is conducted and if the part is found to have a manufacturing defect a credit will be issued.

When returning defective part(s) complete the Return Material Authorization Form and the address label received with the replacement part.

See the STULZ Standard Warranty located in section one of this manual.

5.3 Obtaining Spare/Replacement Parts

Spare and replacement parts requests are to be made through Product Support by fax (301) 620-2606, telephone (888) 529-1266 or E-mail (parts@stulz-ats.com). Quotes are given for specified listed parts for a specific unit.

STULZ accepts Visa and MasterCard. STULZ may extend credit to its customers; a credit application must be prepared and approved (this process could take one week).

A 25% minimum restocking charge will be applied on returned stocked parts that were sold as spare/replacement parts. If the returned part is not a stocked item, a 50% restocking charge may be applied. Additionally a Return Material Authorization Number is required when returning parts. To receive credit for returned repair/replacement parts, the parts must be returned to STULZ within 30 days of the purchase date. Spare part sales over 30 days old will be considered final and the parts will remain the sole property of the ordering party.

STULZ OHS Series Remote Condensing Unit

Appendix A - Forms

STULZ Air Technology Systems Inc.

Frederick, Maryland USA 21704

Telephone: (301) 620-2033 Facsimile: (301) 620-1396

Checklist for Completed Installation

- | | | | |
|----------------------------|---|-----------------------------|---|
| <input type="checkbox"/> 1 | Proper clearances for service access have been maintained around equipment. | <input type="checkbox"/> 8 | Customer supplied main power circuit breaker (HACR type) or fuses have proper ratings for equipment installed. |
| <input type="checkbox"/> 2 | Equipment is level and mounting fasteners are tight. | <input type="checkbox"/> 9 | Control wiring connections completed to remote condensing unit. |
| <input type="checkbox"/> 3 | Piping completed to refrigeration equipment. | <input type="checkbox"/> 10 | All wiring connections are tight. |
| <input type="checkbox"/> 4 | All field installed piping leak tested. | <input type="checkbox"/> 11 | Foreign materials have been removed from inside and around all equipment installed (shipping materials, construction materials, tools, etc.). |
| <input type="checkbox"/> 5 | Refrigerant charge added. | <input type="checkbox"/> 12 | Compressor and fan rotate freely without unusual noise. |
| <input type="checkbox"/> 6 | Incoming line voltage matches equipment nominal nameplated rating \pm tolerances. | <input type="checkbox"/> 13 | Inspect all piping connections for leaks during initial operation. |
| <input type="checkbox"/> 7 | Main power wiring connections to the equipment, including earth ground, have been properly installed. | | |

Frederick, Maryland USA 21704

Telephone: (301) 620-2033

Facsimile: (301) 620-1396

STULZ OHS Series Remote Condensing Unit

Periodic General Maintenance Checks and Services Checklist

Date: _____ Prepared By: _____

Model Number: _____ Serial Number: _____

Item Number: _____

Monthly

| | |
|--------------------------|--|
| <input type="checkbox"/> | Remote Condensing Unit Clean and Clear of Obstructions |
|--------------------------|--|

Semi-Annually

| | | | |
|--------------------------|---|--------------------------|--------------------------------|
| <input type="checkbox"/> | Check Refrigerant Charge (bubbles in sight-glass) | <input type="checkbox"/> | Tighten Electrical Connections |
| <input type="checkbox"/> | Check Suction & Discharge Pressure | <input type="checkbox"/> | Ensure Motor Mount is Secured |
| <input type="checkbox"/> | Ensure Refrigerant Lines are Secured | <input type="checkbox"/> | Clean Unit as Necessary |

Annually

| | |
|--------------------------|---|
| <input type="checkbox"/> | Inspect Refrigerant System for Leaks and Corrosion |
| <input type="checkbox"/> | Conduct a Complete Check of All Services Listed Above and Clean Unit's Interior |

Notes: _____

Signature: _____

*** If factory assistance is required for any reason, provide the serial number, model number, and STULZ item number found on the unit nameplate. This will speed the process and ensure accuracy of information. ***

Appendix B - Acronyms and Abbreviations

| | | | |
|-------------------|--|-------------------|------------------------------------|
| BTU/H- | British Thermal Units Per Hour | MAX FUSE - | Maximum Fuse |
| CFM - | Cubic Feet Per Minute | MCA - | Minimum Circuit Ampacity |
| CNDCT - | Conductor | NEC - | National Electric Code |
| ESD - | Electrostatic Discharge | NFPA - | National Fire Protection Agency |
| °F - | Degrees Fahrenheit | PH - | Phase |
| FLA - | Full Load Amps | PSI - | Pounds Per Square Inch |
| FOB - | Free on Board | psig - | Pounds Per Square Inch Gauge |
| HACR - | Heating, Air Conditioning, Refrigeration | R-Value - | Thermal Resistance |
| HP - | Horse Power | RLA - | Rated Load Amps |
| Hz - | Hertz | SDS - | Safety Data Sheet |
| IAQ - | Indoor Air Quality | SPDT - | Single Pole, Double Throw |
| in - | Inches | STULZ - | STULZ Air Technology Systems, Inc. |
| in. w.g. - | Inches of Water Gauge | TEV - | Thermal Expansion Valve |
| kVA - | Kilo Volt Amp | V - | Volt |
| kW - | Kilowatts | VAC - | Volt, Alternating Current |
| LRA - | Locked Rotor Amps | VDC - | Volt, Direct Current |

NOTES

A large grid area for taking notes, consisting of 20 columns and 30 rows of small squares. The grid is empty and occupies the majority of the page below the 'NOTES' heading.

NOTES

A large grid area for taking notes, consisting of 20 columns and 30 rows of small squares. The grid is empty and occupies the central portion of the page.



STULZ North American Headquarters

STULZ AIR TECHNOLOGY SYSTEMS (STULZ USA), INC.

1572 Tilco Drive | Frederick, MD 21704
 Tel: 301.620.2033 | Fax: 301.662.5487 | info@stulz-ats.com

STULZ Company Headquarters

STULZ GmbH
 Holsteiner Chaussee 283
 22457 Hamburg
 products@stulz.de

STULZ Subsidiaries

STULZ Australia Pty. Ltd.
 34 Bearing Road
 Seven Hills NSW 2147

STULZ Austria GmbH
 Industriezentrum NÖ – SÜD,
 Straße 15, Objekt 77, Stg. 4, Top 7
 2355 Wiener Neudorf

STULZ Belgium BVBA
 Tervurenlaan 34
 1040 Brussels

**STULZ Brasil
 Ar Condicionado Ltda.**
 Rua Canconeiro de Évora, 140
 Bairro - Santo Amaro São
 Paulo-SP, CEP 04708-010

STULZ España S.A.
 Avenida de los Castillos 1034
 28918 Leganés (Madrid)

STULZ France S. A. R. L.
 107, Chemin de Ronde
 78290 Croissy-sur-Seine
 info@stulz.fr

STULZ S.p.A.
 Via Torricelli, 3
 37067 Valeggio sul Mincio (VR)

**STULZ-CHSPL
 (India) Pvt. Ltd.**
 006, Jagruti Industrial Estate
 Mogul Lane, Mahim
 Mumbai - 400016

STULZ México S.A. de C.V.
 Avda. Santa Fe No. 170
 Oficina 2-2-08, German Centre
 Delegación Alvaro Obregon
 MX- 01210 México
 Distrito Federal

STULZ GROEP B. V.
 Postbus 75
 180 AB Amstelveen

STULZ New Zealand Ltd.
 Office 71, 300 Richmond Rd.
 Grey Lynn, Auckland

STULZ Polska SP. Z O.O.
 Budynek Mistral.
 Al. Jerozolimskie 162
 02 – 342 Warszawa

STULZ Singapore Pte Ltd.
 33 Ubi Ave 3 #03-38 Vertex
 Singapore 408868
 andrew.peh@stulz.sg

**STULZ Air Technology and
 Services Shanghai Co., Ltd.**
 Room 406, Building 5
 457 North Shanxi Road
 Shanghai 200040

STULZ South Africa Pty. Ltd.
 Unit 3, Jan Smuts Business Park
 Jet Park, Boksburg
 Gauteng, South Africa

STULZ U. K. Ltd.
 First Quarter,
 Blenheim Rd. Epsom
 Surrey KT 19 9 QN

www.stulz-usa.com